

The Harman Kardon Model HD7625 COMPACT DISC PLAYER

Manual A

Technical Manual

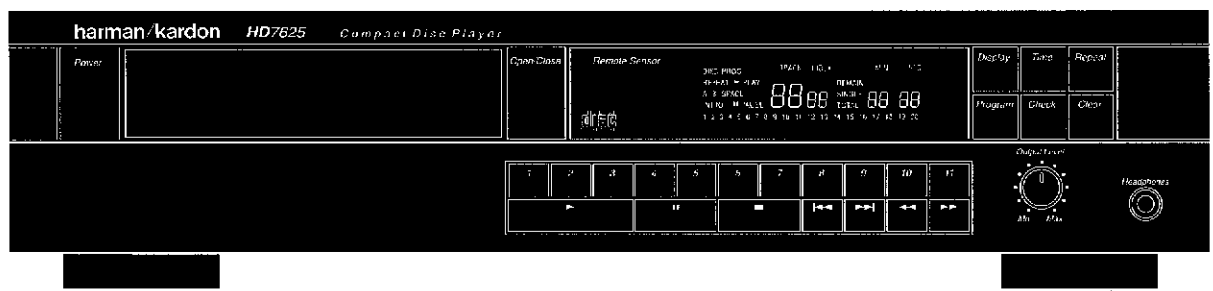

The following marks found in the parts list of this manual identify the models as follows:

- Ⓚ : North America area model Black version
- Ⓜ : International model Black version
- Ⓞ : General Model
- Ⓢ : General Model Black version

harman/kardon

240 Crossways Park West, Woodbury, N. Y. 11797
1112-HD7625-A P9307 1200 Printed in USA

CLASS 1 LASER PRODUCT

Product complies with DHHS rules CFR subchapter J part 1040:10 at date of manufacture.

DANGER - invisible laser radiation when open and interlock failed or defeated. Avoid direct exposure to the beam.

CAUTION - use of all controls, adjustments or performance of procedures other than those specified herein may result in hazardous radiation exposure.



Be careful of the Laser Pickup.

Although you cannot see it from the outside, a laser pickup is located under the disc tray and a precision lens is built in it.

Since the laser pickup, including the lense element, is especially sensitive to dust, keep the disc tray closed when not in use. Also do not put your hand inside the unit.

ADVARSEL:

Usynlig laserstråling ved åbning når sikkerhedsafbrydere er ude af funktion. Undgå udsættelse for stråling.

VAROITUS!

Laite sisältää laseriodin, joka lähettää näkymätöntä silmille vaarallista lasersäteilyä.

CONTENTS

SPECIFICATIONS 1
 SAFETY PRECAUTIONS..... 2
 AC LEAKAGE TEST 2
 ELECTROSTATICALLY SENSITIVE DEVICES 3
 CONTROLS AND FUNCTIONS 4
 REMOTE CONTROL 5
 DISASSEMBLY PROCEDURES 6
 POWER CORD REPLACEMENT 7
 ADJUSTMENT PROCEDURE..... 8
 TROUBLESHOOTING 10
 IC FUNCTIONS 14

CIRCUIT DESCRIPTION 19
 GENERAL UNIT (EXPLODED VIEW) 23
 CD MECHANISM (EXPLODED VIEW) 25
 GENERAL PARTS LIST 26
 CD MECHANISM PARTS LIST 27
 ELECTRICAL PARTS LIST 28
 IC DIAGRAMS..... 33
 P. C. BOARDS 38
 WIRING DIAGRAM..... 40
 SCHEMATIC DIAGRAM..... 41

SPECIFICATIONS

	Nominal	Limit
System	: Compact Disc Digital Audio	
D/A Converter	: Dual 18 Bit Linear D/A Converters, 8Fs Digital Filter, RLS (Real-time Linear Smoothing)	
Signal Detection	: 3-Beam Semiconductor Optical Laser Pickup	
Error Correction	: CIRC System	
Low Level Linearity	: +/-0.5dB @ -90dB	
Frequency Response	0dB	0.5dB
(20Hz to 20kHz)		±
Total Harmonic Distortion (THD)	0.0025%	<0.006%
Dynamic Range	98dB	≥93dB
Signal to Noise Ratio	104dB	≥100dB
Channel Separation	98dB	≥90dB
Line Output Level/Impedance	2.0V	±0.0V 0.5V @ 10k
Digital Output Level/Impedance	0.5Vp-p	0.5Vp±p 0.1Vp-p @75
Power Supply	: AC230/240V, 50/60Hz ± Ω	
Power Consumption	: 22 Watts	
Dimensions	: 17 3/8" x 4" x 13"	
	: 443mm x 103mm x 326mm	
Weight	: 12.3lbs/5.6kg	

Specifications and components subject to change without notice. Overall performance will be maintained or improved.

SAFETY PRECAUTIONS

Before returning an instrument to the customer, always make a safety check of the entire instrument, including, but not limited to, the following items:

- a. Be sure that no built-in protective devices are defective and/or have been defeated during servicing.
 - (1) Protective shields are provided to protect both the technician and the customer. Correctly replace all missing protective shields, including any removed for servicing convenience.
 - (2) When reinstalling the chassis and/or other assembly in the cabinet, be sure to put back in place all protective devices, including, but not limited to, nonmetallic control knobs, insulating fishpapers, adjustment and compartment covers/shields, and isolation resistor/capacitor networks.

Do not operate this instrument or permit it to be operated without all protective devices correctly installed and functioning.

- b. Be sure that there are no cabinet openings through which an adult or child might be able to insert their fingers and contact a hazardous voltage. Such openings include, but are not limited to, excessively wide cabinet ventilation slots, and an improperly fitted and/or incorrectly secured cabinet back cover.
- c. **Leakage Current Hot Check** - With the instrument completely reassembled, plug the AC line cord directly into a 120V AC outlet (do not use an isolation transformer during this test). Use a leakage current tester or a metering system that complies with American National Standards Institute (ANSI) C101.1 "Leakage Current for Appliances" and Underwriters Laboratories (UL) 1270, (34.6). With the instrument AC switch first in the ON position and then in the OFF position, measure from a known earth ground (metal waterpipe, conduit, etc.) to all exposed metal parts of the instrument (antennas, handle bracket, metal cabinet, screwheads, metallic overlays, control shafts, etc.), especially any exposed metal parts that offer an electrical return path to the chassis. Any current measured must not exceed 0.5 milliamp. Reverse the instrument power cord plug in the outlet and repeat test. **ANY MEASUREMENTS NOT WITHIN THE LIMITS SPECIFIED HEREIN INDICATE A POTENTIAL SHOCK HAZARD THAT MUST BE ELIMINATED BEFORE RETURNING THE INSTRUMENT TO THE CUSTOMER.**

AC LEAKAGE TEST

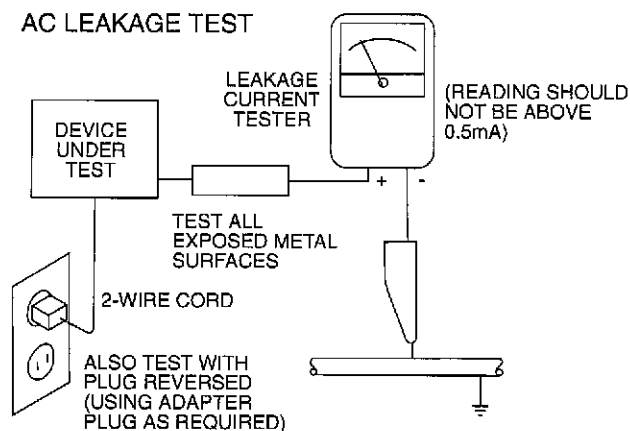

d. Insulation Resistance Test

- (1) Unplug the power supply cord and connect a jumper wire between the two prongs of the plug.
- (2) Turn on the power switch of the instrument.
- (3) Measure the resistance with an ohmmeter between the jumpered AC plug and each **exposed metallic** cabinet part on the instrument, such as screwheads, antenna, control shafts, handle brackets, etc. The reading should be as shown below. If it is not within the limits specified, there is the possibility of a shock hazard, and the instrument must be repaired and rechecked before it is returned to the customer.

e. Insulation Resistance Test Cold Check

- (1) Unplug the power supply cord and connect a jumper wire between the two prongs of the plug.
- (2) Turn on the power switch of the instrument.
- (3) Measure the resistance with an ohmmeter between the jumpered AC plug and each exposed **metallic cabinet** part on the instrument, such as screw heads, antenna, control shafts, handle brackets, etc. When the exposed metallic part has a return path to the chassis, the reading should be between 1 and 5.2 Megohm. When there is no return path to the chassis, the reading must be "infinite". If it is not within the limits specified, there is the possibility of a shock hazard, and the instrument must be repaired and rechecked before it is returned to the customer.

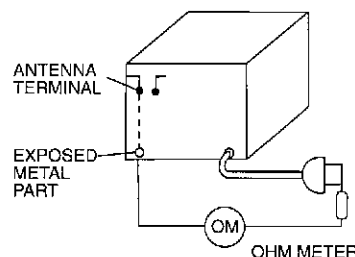

PRODUCT SAFETY NOTICE

Some electrical and mechanical parts have special safety-related characteristics which are often not evident from visual inspection, nor can the protection they give necessarily be obtained by replacing them with components rated for higher voltage, wattage, etc. Parts that have special safety characteristics are identified by shading, by (Δ) on schematics and parts list. Use of a substitute replacement that does not have the same safety characteristics and parts listed. Use of a substitute replacement that does not have the same safety characteristics as the recommended replacement part might create shock, fire, and/or other hazards. Products Safety is under review continuously and new instructions are issued whenever appropriate.

SERVICING PRECAUTIONS

CAUTION: Before servicing instruments covered by this manual and its supplements, read and follow the SAFETY PRECAUTIONS on this page.

NOTE: If unforeseen circumstances created conflict between the following servicing precautions and any of the safety precautions, **always follow the safety precautions.** Remember: Safety First.

General Servicing Precautions

- a. Always unplug the instrument's AC power cord from the AC power source before:
 - (1) Removing or reinstalling any component, circuit board, module, or any other instrument assembly.
 - (2) Disconnecting or reconnecting any instrument electrical plug or other electrical connection.
 - (3) Connecting a test substitute in parallel with an electrolytic capacitor in the instrument.

Caution: A wrong part substitution or incorrect polarity installation of electrolytic capacitors may result in an explosion hazard.
- b. Do **not** defeat any plug/socket B+ voltage interlocks with which instruments covered by this manual might be equipped.
- c. Do **not** apply AC power to this instrument and/or any of its electrical assemblies unless all solid-state device heat sinks are correctly installed.
- d. Always connect a test instrument's ground lead to the instrument chassis ground before connecting the test instrument positive lead. Always remove the test instrument ground lead last.

NOTE: Refer to Safety Precautions on Page 2.

- (1) The service precautions are indicated or printed on the cabinet, chassis or components. When servicing, follow the printed or indicated service precautions and service materials.
- (2) The Components used in the unit has a specified conflammability and dielectric strength. When replacing any components, use components which has the same ratings. Components marked (Δ) in the circuit diagram are important for safety or for the characteristics of the unit. Always replace with the appointed components.
- (3) An insulation tube or tape is sometimes used and some components are raised above the printed wiring board for safety. The internal wiring is sometimes clamped to prevent contact with heating components. Install them as they were.
- (4) After servicing, always check that the removed screws, components and wiring have been installed correctly and that the portion around the service part have not been damaged and so on. Further check the insulation between the blades of attachment plug and accessible conductive parts.

Insulation Checking Procedure

Disconnect the attachment plug from the AC outlet and turn the power on. Connect the insulation resistance meter (500V) to the blades of the attachment plug. The insulation resistance between each blade of the attachment plug and accessible conductive parts (Note 1) should be more than 1M-ohm.

NOTE: Accessible Conductive Parts including Metal panels, Output jacks, etc.

ELECTROSTATICALLY SENSITIVE (ES) DEVICES

Some semiconductor (solid state) devices can be damaged easily by static electricity. Such components commonly are called Electrostatically Sensitive (ES) Devices. Examples of typical ES devices are integrated circuits and some field effect transistors and semiconductor "chip" components. The following techniques should be used to help reduce the incidence of component damage caused by static electricity.

- 1. Immediately before handling any semiconductor component or semiconductor-equipped assembly, drain off any electrostatic charge on your body by touching a known earth ground. Alternatively, obtain and wear a commercially available discharging wrist strap device, which should be removed for potential shock reasons prior to applying power to the unit under test.
- 2. After removing an electrical assembly equipped with ES devices, place the assembly on a conductive surface such as aluminum foil, to prevent electrostatic charge buildup or exposure of the assembly.
- 3. Use only a grounded-tip soldering iron to solder or unsolder ES devices.
- 4. Use only an anti-static solder removal device. Some solder removal devices not classified as "anti-static" can generate electrical charges sufficient to damage ES devices.
- 5. Do not use freon-propelled chemicals. These can generate electrical charge sufficient to damage ES devices.
- 6. Do not remove a replacement ES device from its protective package until immediately before you are ready to install it. (Most replacement ES devices are packaged with leads electrically shorted together by conductive foam, aluminum foil or comparable conductive material.)
- 7. Immediately before removing the protective material from the leads of a replacement ES device, touch the protective material to the chassis or circuit assembly into which the device will be installed.

CAUTION: Be sure no power is applied to the chassis or circuit, and observe all other safety precautions.
- 8. Minimize bodily motions when handling unpackaged replacement ES devices. (Otherwise harmless motion such as the brushing together or your clothes fabric or the lifting of your foot from a carpeted floor can generate static electricity sufficient to damage an ES device.)

CONTROLS AND FUNCTIONS

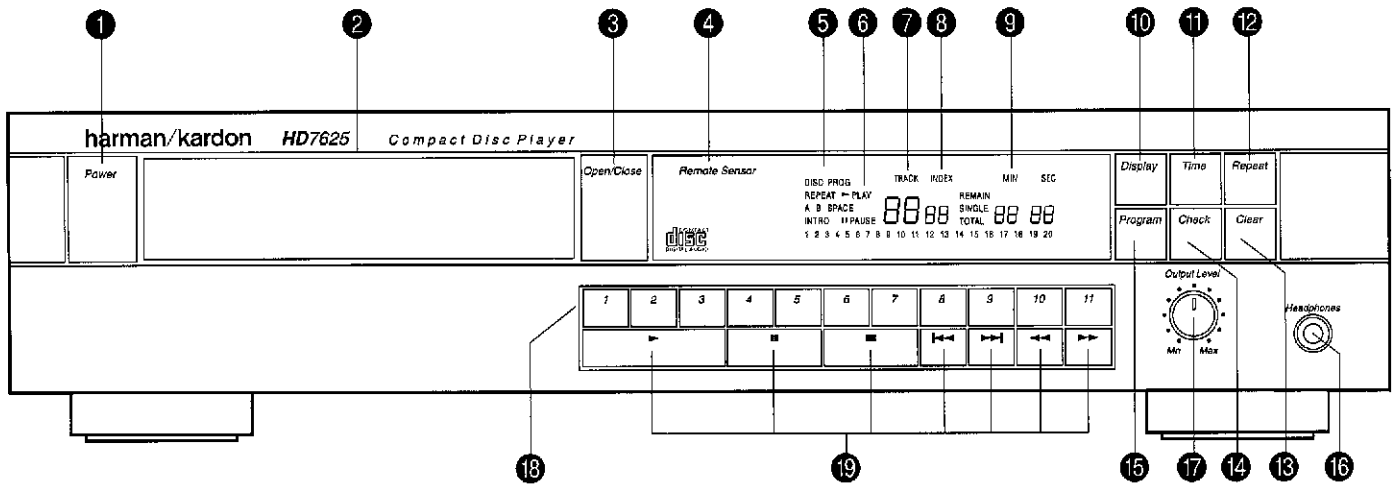

1 POWER switch

The POWER switch turns the unit on and off.

2 Compact disc drawer

Load a disc (full-size or 3-inch/8cm) into your compact disc player by placing it in this drawer with the label side up. Open and close the drawer using the OPEN/CLOSE button (3).

3 OPEN/CLOSE button

Press this button to open or close the compact disc drawer. The drawer will also close if you press the play button or push the drawer gently toward the chassis of the player; however, we recommend that you do not push the drawer.

4 REMOTE sensor

This area receives the signal from the remote control unit. Make sure this area of the front panel is kept free from dirt or other obstructions that might prevent proper reception of the infrared signal from the remote control.

5 FUNCTION indicator

DISC - This indicator lights when the disc drawer is open, and when a disc is loaded. It does not light when there is no disc.

REPEAT - When this indicator is lit, the unit is in REPEAT mode and will continuously repeat either the entire disc or the programmed sequence.

A-B - When this indicator is lit steadily, the unit is set to repeat a specified section of the disc (from A to B). When REPEAT indicator is lit, you have already programmed the starting point (point A) of a section, and the unit is waiting for you to program the ending point of the section (point B).

INTRO - When this indicator is lit, the unit is in INTRO SCAN mode and will play only the first 15 seconds of each selection on the disc or in the selected program.

PROG - When this indicator is lit, the unit is in PROGRAM mode, in which you can program a sequence of tracks in the order you'd like to hear them, then play back your programmed sequence.

SPACE - When this indicator is lit, the unit is in SPACE mode and will insert 4 seconds of space between tracks.

6 PLAYBACK mode

PLAY - This indicator is lit when the unit is playing a track.

PAUSE - This indicator is lit when the unit is in PAUSE mode (i.e., you have pressed PAUSE to temporarily stop playback).

7 TRACK indicator

When a disc is loaded but not playing, the TRACK indicator displays the total number of tracks on that disc. During playback, the indicator displays the number of the track currently being played. During programming, it displays the number of the track most recently selected.

8 INDEX indicator

Some discs that contain very long tracks may have those tracks subdivided into shorter sections. For example, a long classical piece may be divided into movements, each of which may have an index number. The INDEX indicator displays the number of the subdivision of a track currently being played. If the track has no subdivisions, the INDEX indicator will display a 1 during playback. During programming, the INDEX light goes out and the indicator displays the total number of tracks selected in the programmed sequence.

9 TIME indicator

When a disc is loaded but not playing, the TIME indicator displays the total amount of playback time on that disc. During playback, depending on the state of the TIME button (11), the indicator displays one of the following:

- The time that has elapsed since the beginning of the current track.
- The time that remains on the currently selected track. The words REMAIN SINGLE will be displayed if the indicator is in this mode.
- The time that remains on either the entire disc or on the programmed selections. The words REMAIN TOTAL will be displayed if the indicator is in this mode. Note that if you have programmed more than 99 minutes in your selection, only dashes will appear in this mode.

10 DISPLAY button

This button turns the display on and off. When you turn the display off in PLAY mode, the entire display goes off. In PAUSE mode, most of the display goes off, but the track number is still displayed. In STOP mode, most of the display goes off, but the total number of tracks on the disc is still displayed. In some systems, turning the fluorescent display off may provide the purest possible sound quality during playback.

11 TIME button

During playback or programming, the button cycles through the three TIME display modes:

- The time that has elapsed since the beginning of the current track.
- The time that remains on the currently selected track.
- The time that remains on either the entire disc or the programmed sequence.

12 REPEAT button

This button puts your compact disc player in and out of REPEAT mode. In REPEAT mode, the unit will continually play back either the entire disc or the programmed sequence of tracks. Press the button once to turn on REPEAT mode; press again to turn off REPEAT mode. When the unit is in REPEAT mode, the FUNCTION indicator (5) will display the word REPEAT.

13 CLEAR button

The CLEAR button removes tracks from your programmed sequence one by one starting with the last track entered. Each time you clear a track from the programmed sequence, that track's time is deleted from the total time displayed. This button is used only in PROGRAM mode.

14 CHECK button

When a disc is loaded but not playing (STOP mode), you can press the CHECK button to see the playback time of each track on the disc. Each time you press the CHECK button, the next track is displayed along with its playback time. When you have stepped sequentially through all the tracks on the disc, another press of the CHECK button displays the total playback time of the entire disc. In PROGRAM mode, the CHECK button displays the cumulative time of the tracks in the programmed sequence. That is, the first press displays the time of the first programmed track, the second press displays the cumulative playback time of the first and second tracks, and so on.

15 PROGRAM button

This button puts your compact disc player in and out of PROGRAM mode. Press the button once to turn on PROGRAM mode; press again to turn it off. In PROGRAM mode, you can program a set of tracks to play in any sequence. (For instructions on programming a sequence of tracks, see the Operations section of this manual.) When the unit is in PROGRAM MODE, the function indicator (5) will display the word PROG in red.

16 HEADPHONES jack

Stereo headphone with a standard 1/4" (6.5 mm) plug can be connected to this jack.

17 OUTPUT LEVEL control

This knob controls the volume of the variable output jacks on the rear panel as well as the headphone volume. You can use this output volume control to match the volume of your compact disc player with the volume of your turntable or tuner. In systems where the compact disc player is connected directly to the power amplifier, the OUTPUT LEVEL control provides the volume control for the system.

18 Track selection buttons

This set of buttons (numbered 1 through 10 and +10) enables you to directly select the track you want to play. To select a

track with a number higher than 10, press the +10 button, then press the button that will add up to the number of the track you want. For example, to select track 14, press +10, then press 4. If you select a track number that does not exist on your disc, the TRACK indicator will continue to display the number of the last track on the disc. When PROGRAM mode is off, pressing a track button plays the track you select. When PROGRAM mode is on, pressing a track button programs that track into your sequence.

19 Playback controls

PLAY -- The PLAY button starts playback of a track.

PAUSE -- Pressing the PAUSE button temporarily stops playback. Pressing the PAUSE button again, or pressing PLAY, resumes playback at the precise point where playback left off.

STOP -- The STOP button stops playback. When you press PLAY, playback will start either at the beginning of the disc or programmed sequence, or at any track you select.

SKIP BACK -- Pressing this button once skips back to the beginning of the present track. If you are in PLAY mode, playback will resume. Holding the button down skips backward to the beginning of each preceding track until the first track on the disc is reached.

SKIP FORWARD -- Pressing this button once skips forward to the beginning of the next track. If you are in PLAY mode, playback will resume. Holding the button down skips forward to the beginning of each subsequent track until the last track on the disc is reached.

SEARCH BACK -- Holding down this button during playback reverses rapidly through the disc. This function is similar to the "rewind" function on a tape deck.

SEARCH FORWARD -- Holding down this button during playback speeds rapidly forward through the disc. This function is similar to the "fast forward" function on a tape deck.

REMOTE CONTROL

The remote control for the HD7625 provides the same functions found on the front panel of the compact disc player itself. In addition, the remote control provides some functions that are not found on the front panel.

For the HD7625, the functions found on the remote control that are not found on the front panel are INTRO, A-B, INDEX, and SPACE. These four functions are described below (for other functions, see the descriptions above).

20 A-B button

This button puts your compact disc player in and out of A-B mode. In A-B mode, the unit will continually play back a "Phrase" or section of your disc beginning at point A and ending at point B. (For instructions on repeating a section of a disc, see the Operations section of this manual.) When the unit is in A-B mode, the FUNCTION indicator (5) will display REPEAT A-B. This feature is available on the HD7625 only through the A-B button on the remote control.

21 INTRO button

This button puts your compact disc player in and out of INTRO SCAN mode. When INTRO SCAN is on and you press PLAY, the unit plays only the first 15 seconds of each track before moving on to the next. Press the button once to turn on INTRO

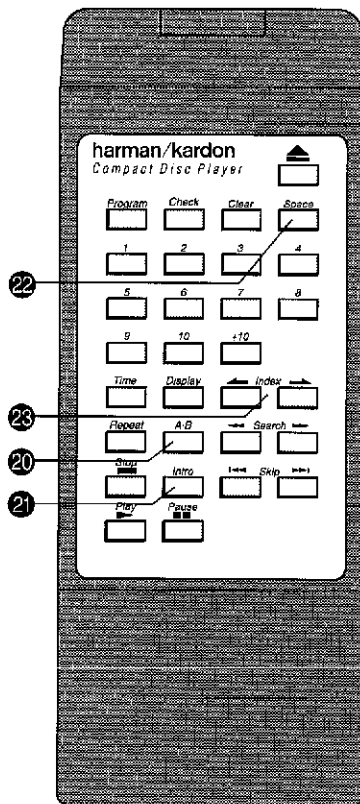

DISASSEMBLY PROCEDURES

[1] CABINET TOP (124) REMOVAL

Remove 7 screws (A) and then remove the Cabinet Top (124).

[2] FRONT PANEL ASSEMBLY (AA) REMOVAL

1. Remove the Cabinet Top (124), referring to the previous step [1].
2. Disconnect the connector with lead wires (JL401) from connectors (CN201) on the Main P. C. Board (PCB-1).
3. Remove lead wire (W401) from the Main P. C. Board (PCB-1).
4. Disconnect the wires (W-510 and W-511) from the chassis, by removing two nuts (208 and 209).
5. Remove 6 screws (B) and then remove the Front Panel Assembly (AA) with the Front P. C. Board (PCB-2) and the Output Level & Jack P. C. Board (PCB-3).
6. Pull off output level Knob (134). Remove nut (D) and then remove the Output Level and Jack P. C. Board (PCB-3) from the Front Panel Assembly (AA).
7. Remove 9 screws (C) and then remove the Front P. C. Board (PCB-2) from the Front Panel Assembly (AA).

[3] MAIN P. C. BOARD (PCB-1) REMOVAL

1. Remove the Cabinet Top (124), referring to the previous step [1].
2. Disconnect the connector with lead wires (LCN113, LCN114, LCN115 and LCN117) from connectors (CN113, CN114, CN115 and CN117) on the Main P. C. Board (PCB-1).
3. Open the lid of connectors (CN501, CN502 and CN503) on the Main P. C. Board (PCB-1), then disconnect the lead wires (W501, W502 and W503). Also Open the lid of connectors (CN1 and CN2) on the Main P. C. Board (PCB-1), then disconnect the lead wires (JL1 and JL2).
4. Remove 11 screws (E), then remove the Main P. C. Board (PCB-1)

[4] POWER SUPPLY P. C. BOARD (PCB-5) REMOVAL

1. Remove 6 screws (G) and four washers (212).
2. Disconnect lead wires (TM1 and TM2) on the Power Supply P. C. Board (PCB-5).
3. Open the lid of connectors (CN1 and CN2) on the Main P. C. Board (PCB-1), then disconnect the lead wires (JL1 and JL2).
4. Slide back the Power Supply P. C. Board (PCB-5) to disconnect power switch shaft from the Front Panel Assembly (AA) and remove.

[5] CD PLAYER MECHANICAL ASSEMBLY (104) REMOVAL

1. Remove the Cabinet Top (124), referring to the previous step [1].

SCAN mode; press again to turn it off and stop the scanning. When the unit is in INTRO SCAN mode, the FUNCTION indicator (5) will display the word INTRO. This feature is available on the HD7625 only through the INTRO button on the remote control.

22 SPACE button

This button puts you compact disc player in and out of SPACE mode. Press the button once to turn on SPACE mode; press again to turn it off. In SPACE mode, the unit inserts 4 seconds of blank space between tracks. This is particularly useful if you are recording music from a compact disc onto a tape. Tape decks with a Music Search feature will be able to use the 4 seconds of space to correctly identify the beginning of each selection on the tape. When the unit is in SPACE mode, the FUNCTION indicator (5) will display the word SPACE.

23 INDEX buttons

Some discs contain long selections that may be subdivided into shorter section (for example, operas). Just as the tracks are marked by the track number, these shorter sections may be marked by index numbers. When you have started playback of the desired track, you can use the INDEX UP and INDEX DOWN buttons to jump to a desired index selection. Each time you press an INDEX button, the INDEX indicator displays the next higher or lower index number. If you continue pressing the button until the indicated index number is higher than the actual number of index selections on the disc, playback will start from the nearest index selection.

2. Disconnect the connector with lead wires (LCN113, LCN114, LCN115 and LCN117) from connectors (CN113, CN114, CN115 and CN117) on the Main P. C. Board (PCB-1).
3. Remove 3 screws (F) and then remove the CD Player Mechanical Assembly (104) backward.

DISASSEMBLING THE CD PLAYER MECHANICAL ASSEMBLY

[6] DISC TRAY (1) REMOVAL

1. Remove the Cabinet Top (124), referring to the previous step [1].
2. Connect the Power cord and turn on the power by pressing the Power switch.
3. Open the Disc Tray (1) by pressing the Open/Close button.
4. With the Disc Tray (1) opened as it is, pull out the power plug.
5. Push the Disc Tray (1) by hand to slide it in once.
6. Loosen the 2 screws (H) and then slide out the Disc Tray (16) by hand.

[7] OPTICAL PICK-UP (57) REMOVAL

1. Remove the CD Player Mechanical Assembly (104), referring to the previous step [5].
2. Remove 4 screws (I) and then remove the Disc Motor, Pick-up and Slide Motor Assembly (13) from the CD Player Mechanical Assembly (104).
3. Remove gear (58) by gently pressing at its base, to release it and pull it out of the Disc Motor, Pick-up and Slide Motor Assembly (13).
4. Slide the sled shaft (51) towards the disc motor and at the same time open sled shaft stop (J). Gently slide the sled shaft (51) out of the Disc Motor, Pick-up and Slide Motor Assembly (13).
5. Remove the Optical Pick-Up (57) from the Disc Motor, Pick-up and Slide Motor Assembly (13).

[8] SLIDE MOTOR (60) REMOVAL

1. Unsolder the terminals of the Disc and Slide Motors, then remove the Motor P. C. Board (61).
2. Remove 2 screws (k) and then remove the Slide Motor (60).

POWER CORD REPLACEMENT (FOR SERVICE ENGINEERS OTHER THAN NORTH AMERICA)

In order to prevent fire or shock hazard when replacing the power cord, follow the procedure below to replace the part with the standard supply parts.

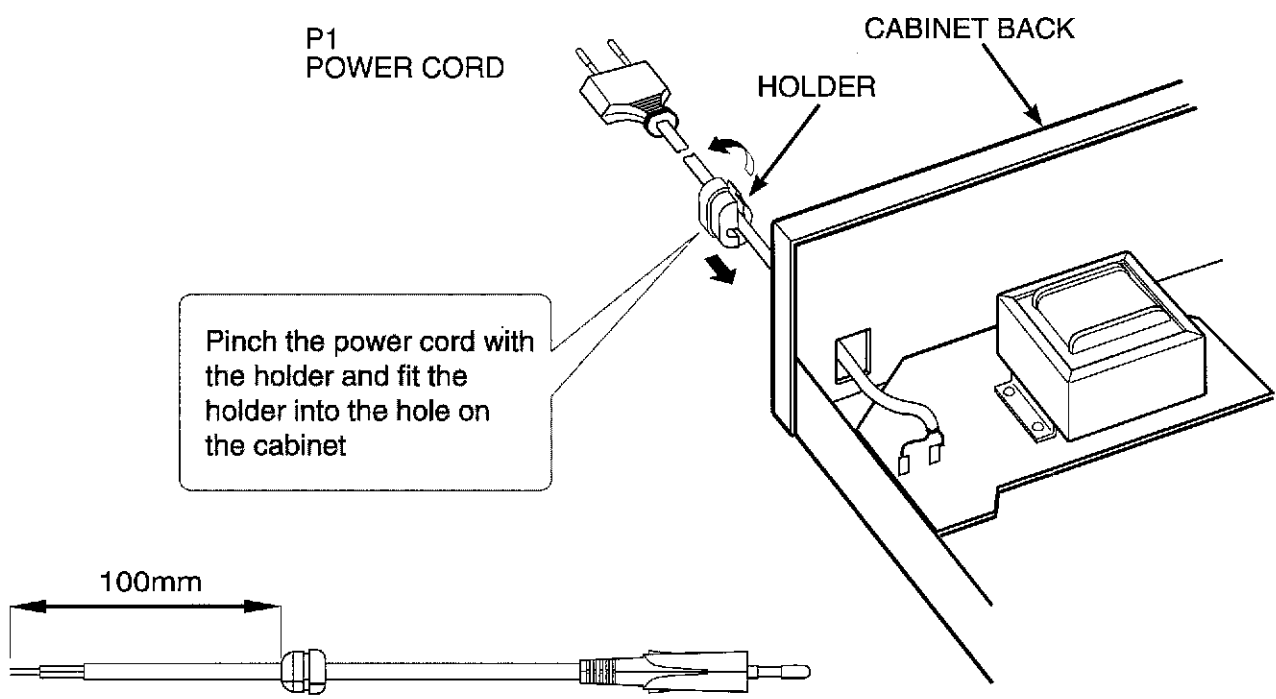

ADJUSTMENT PROCEDURE

1. Instruments required

- DC voltmeter
- Oscilloscope (3 or more modes, 100MHz, input select DC range)
- Jitter meter
- Test disc: EIAJ CD-1

2. Adjustment points

2-1 Adjusting screw layout for CD player mechanical assembly.

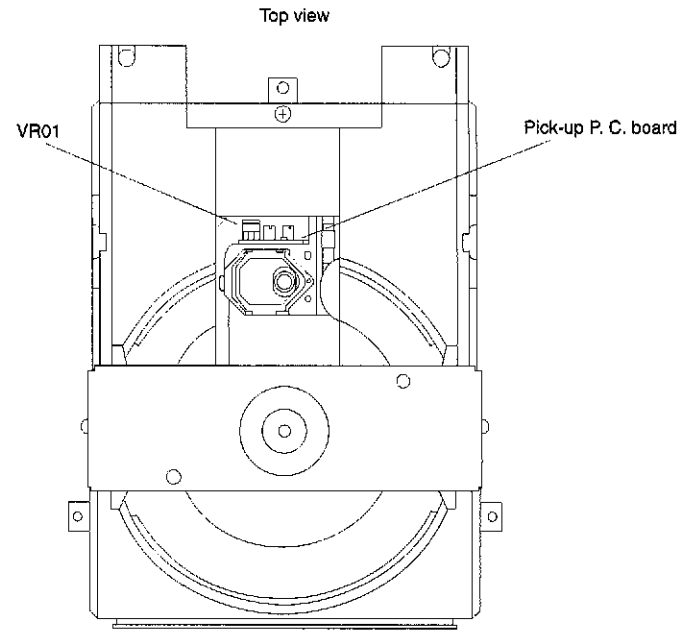

2-2 VR and test point layout for main P.C. board.

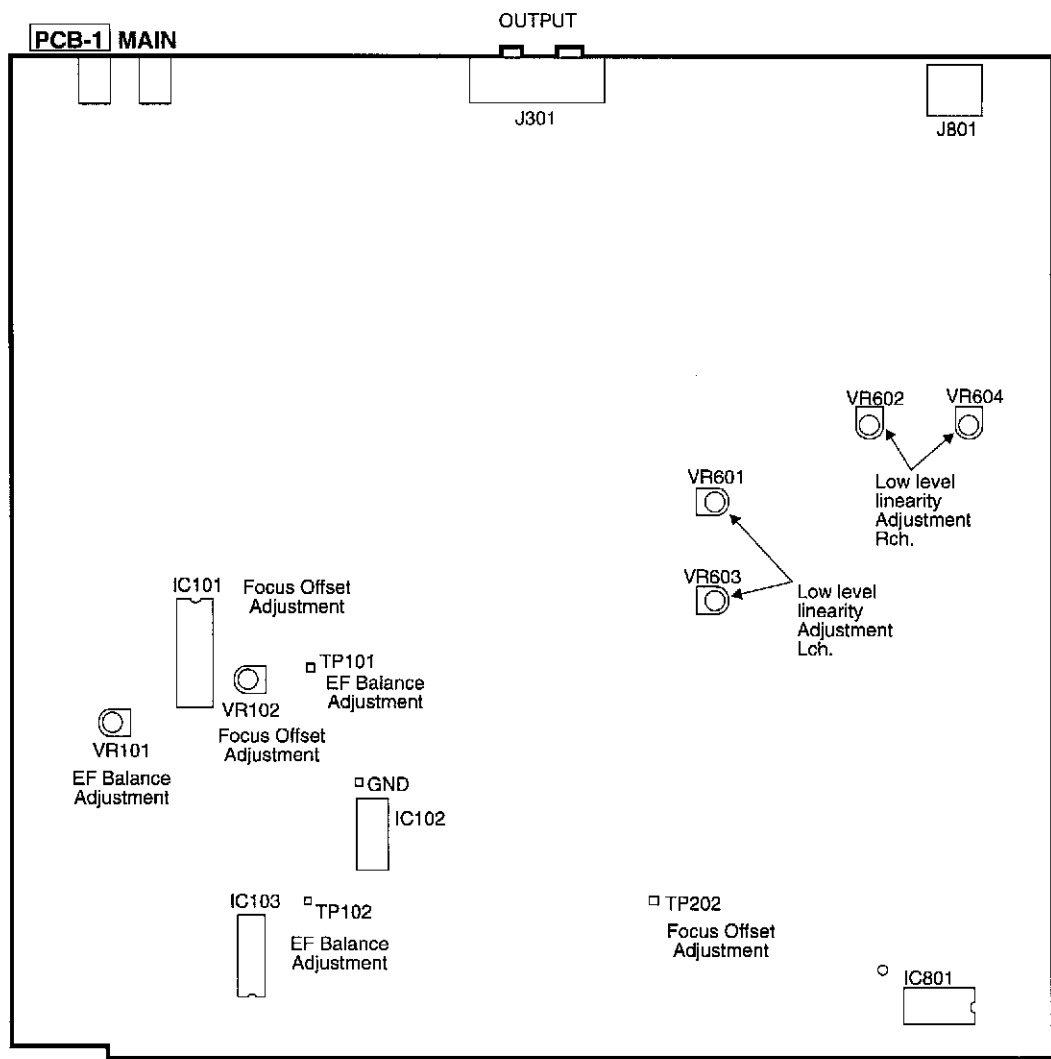

ADJUSTMENT POINT

3. Optical Pick-up Laser Power Adjustment

The specified value for adjustment varies with the type of the pick-up in use. Obtain the voltage value according to the following procedure.

- (a) Read the current value on the label of the pick-up P.C. board.
- (b) Using the amperage of the current and the following equation, calculate the voltage value. When the current is 44.1mA; $V=0.0441A \times 22=0.9702V$.
- (1) Connect the DC voltmeter to both ends of R101.
- (2) Insert EIAJ CD-1 test disc and place the unit in the Play mode.
- (3) Adjust VR01 in the pick-up P.C. board to the voltage obtained in step (b) above.

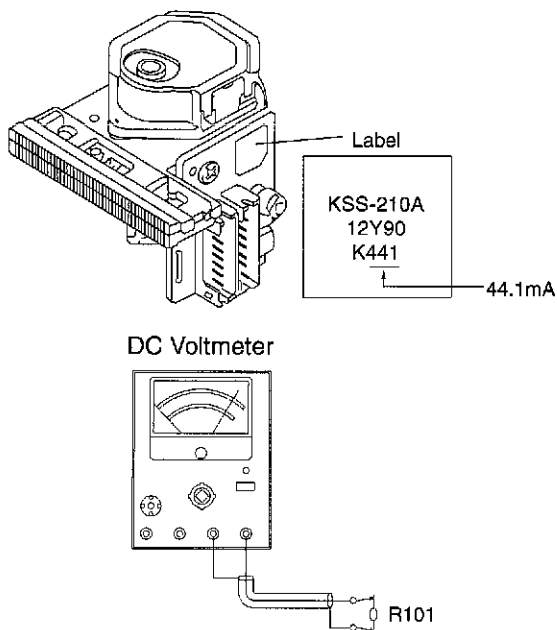

4. EF Balance Adjustment

- (1) Connect the oscilloscope (0.5V/div, 5msec./div, DC mode) to TP101 and GND. Short-circuit TP401 and GND.
- (2) Insert EIAJ CD-1 test disc and place the unit in the Play mode.
- (3) Adjust VR101 so that the amplitude above and below the zero DC line becomes equal (Amplitude A = Amplitude B).

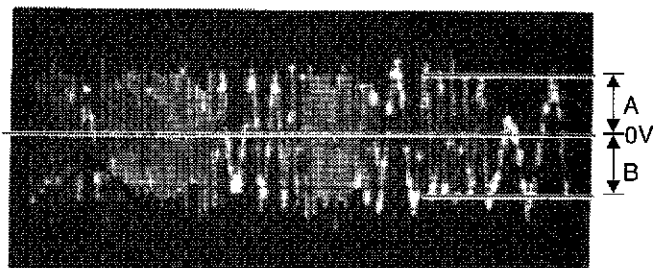
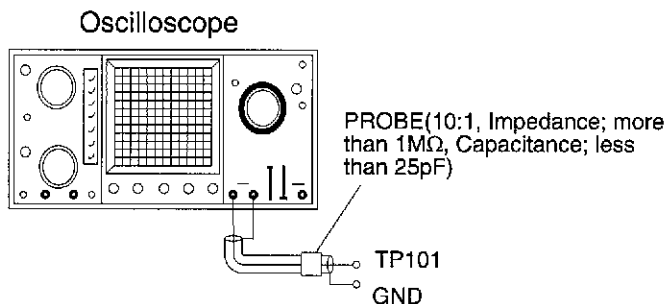

A=B

(approx. 1.5Vp-p)

5. Focus Offset Adjustment

- (1) Connect the Jitter meter to TP201 and GND.
- (2) Insert EIAJ CD-1 test disc and place the unit in the Play mode.
- (3) Adjust VR102 until the jitter for optimum sensitivity.

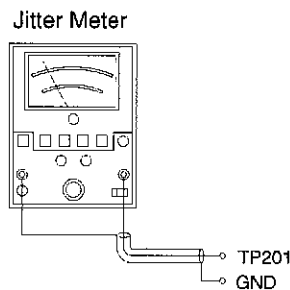

6. Jitter Inclination Confirmation

- (1) Connect the Jitter meter (sigma range) to TP201 and GND.
- (2) Insert EIAJ CD-1 test disc and place the unit in the Play mode.
- (3) Confirm the jitter meter reading is less than 30ns.

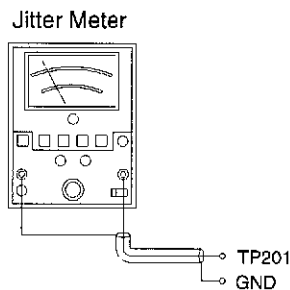

Troubleshooting

When a problem occurs, first check the pick-up lens for dirt and each connector for tight and secure connection. If the problem persists after checking both of these items, use the following check procedures.

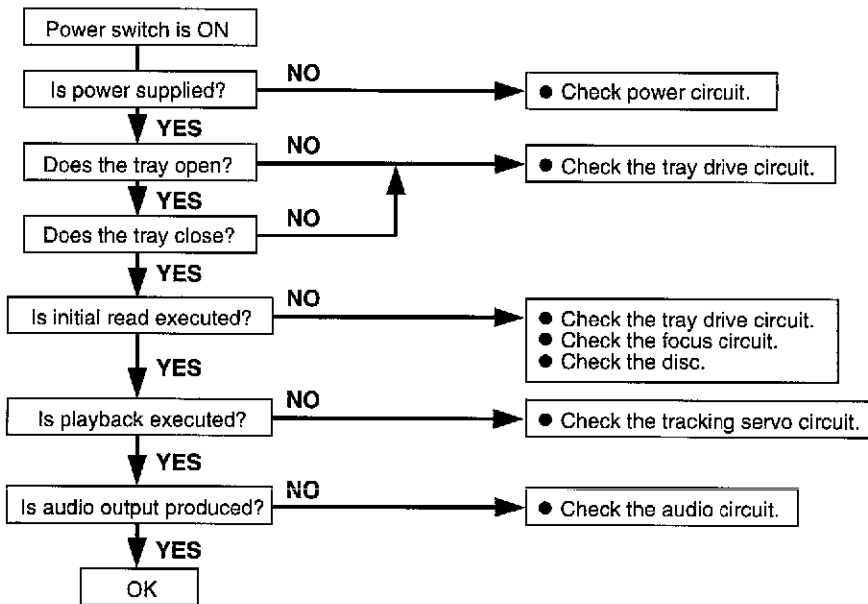

(1) When Multi Display fails to light properly.

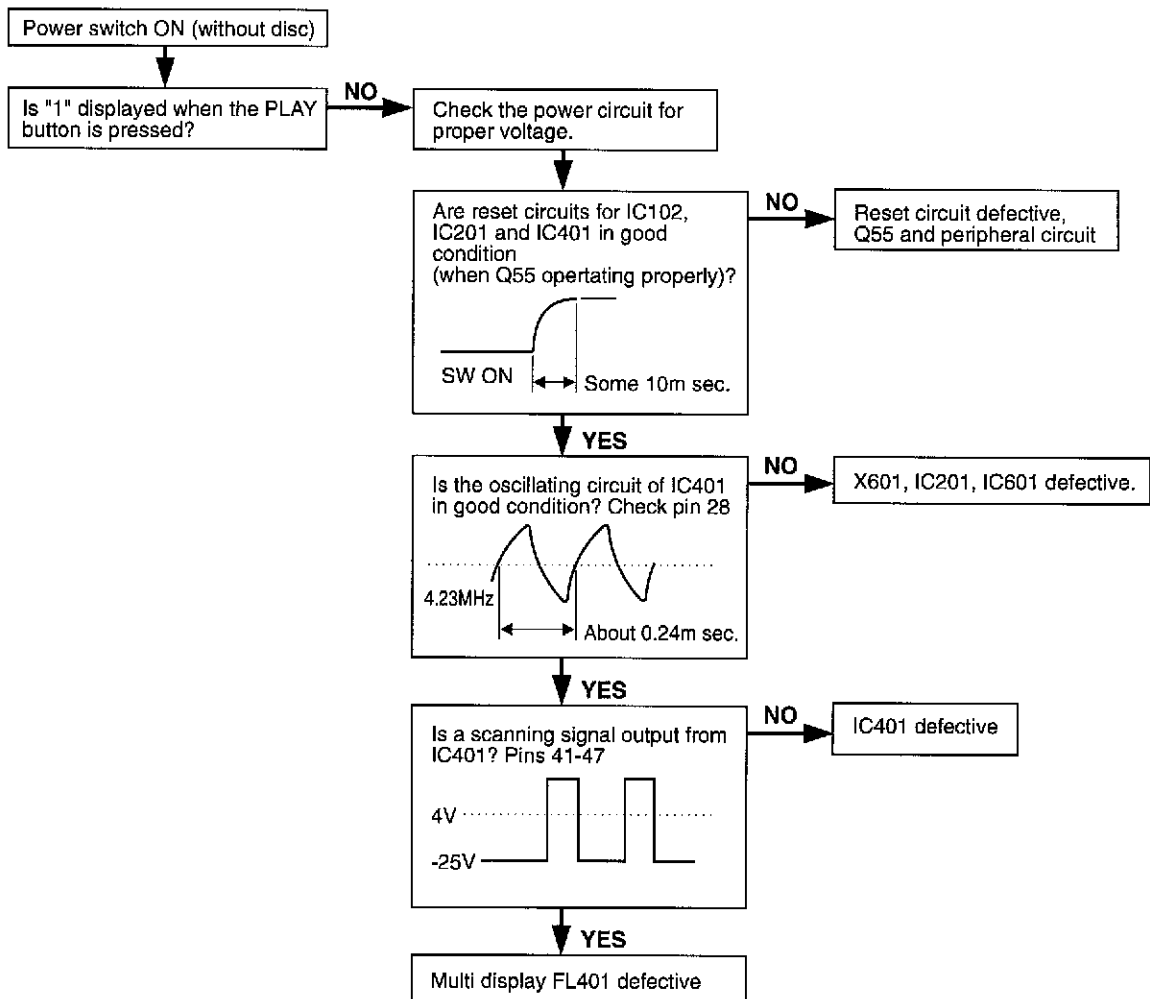

When a problem occurs, first check the pick-up lens for dirt and each connector for tight and secure connection. If the problem persists after checking both of these items, use the following check procedures.

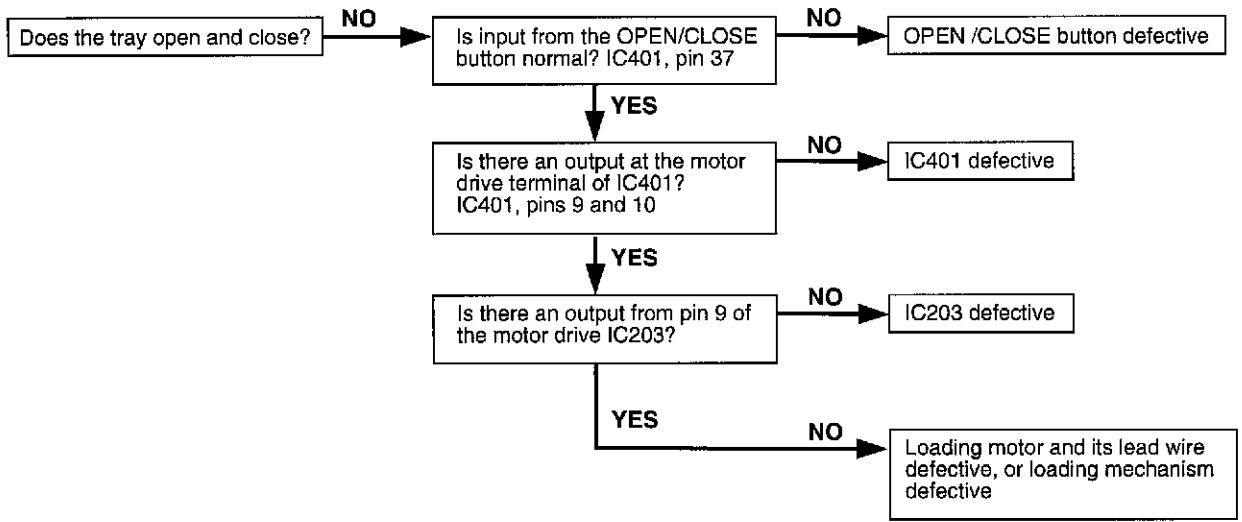

(3) When initial read cannot be executed.

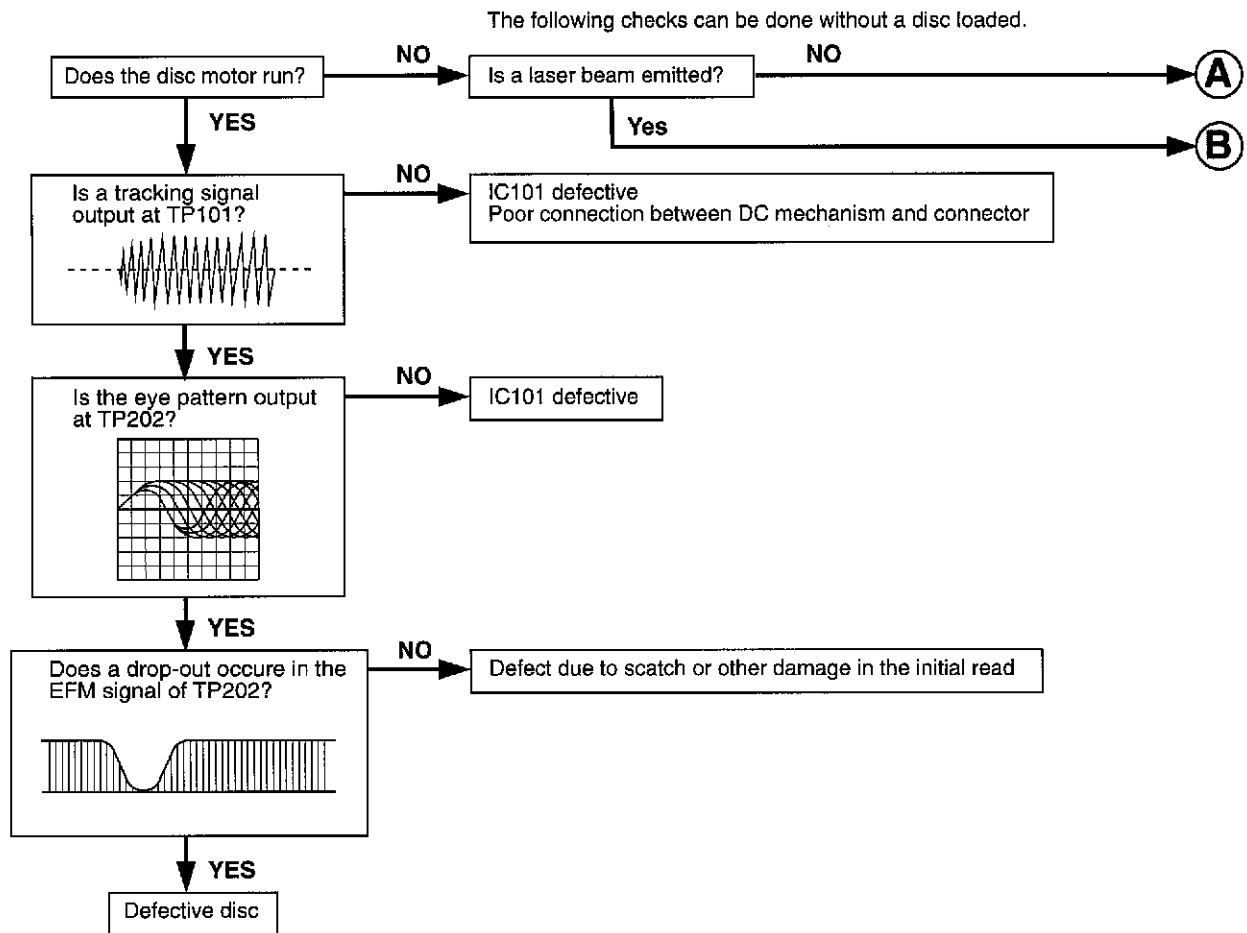

(A) When Laser not emitted.

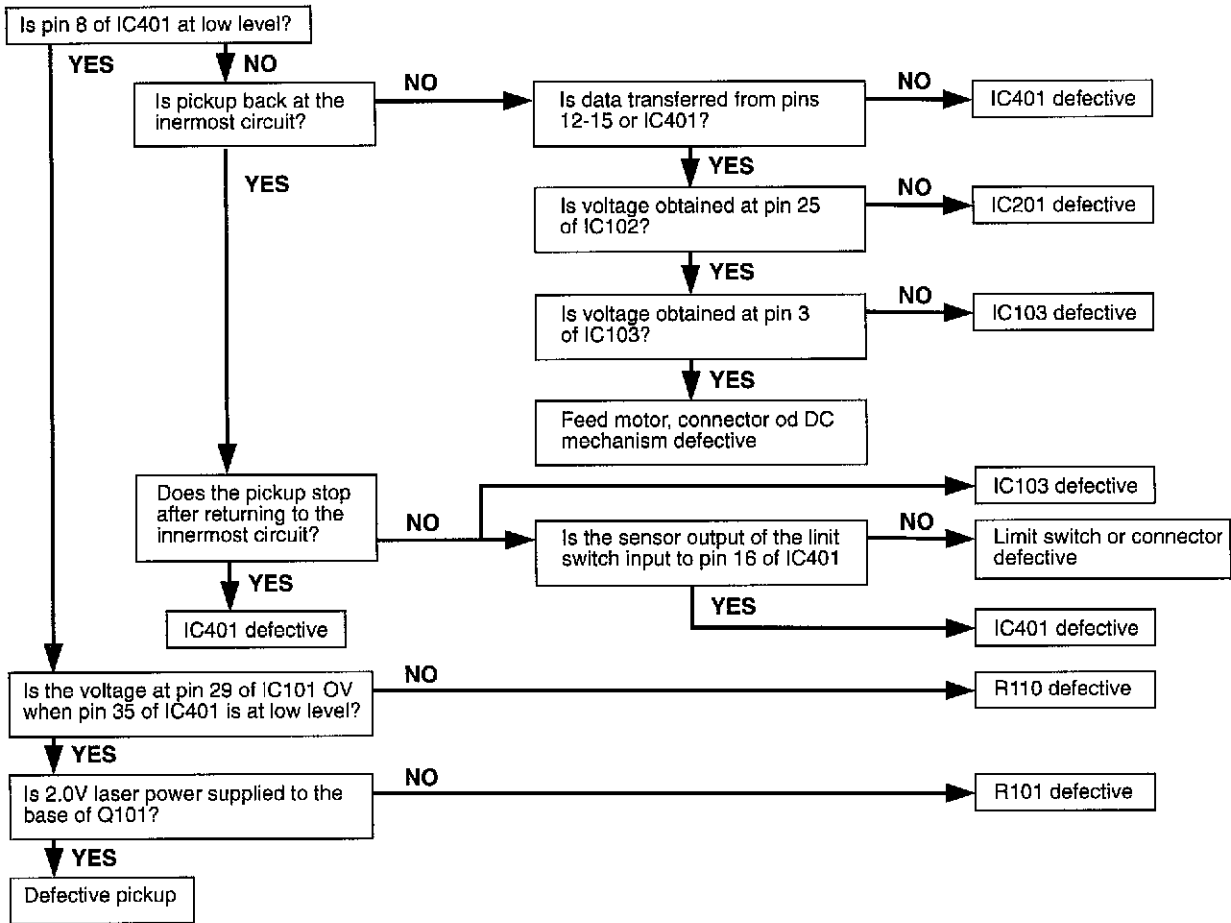

(B) When Laser is emitted.

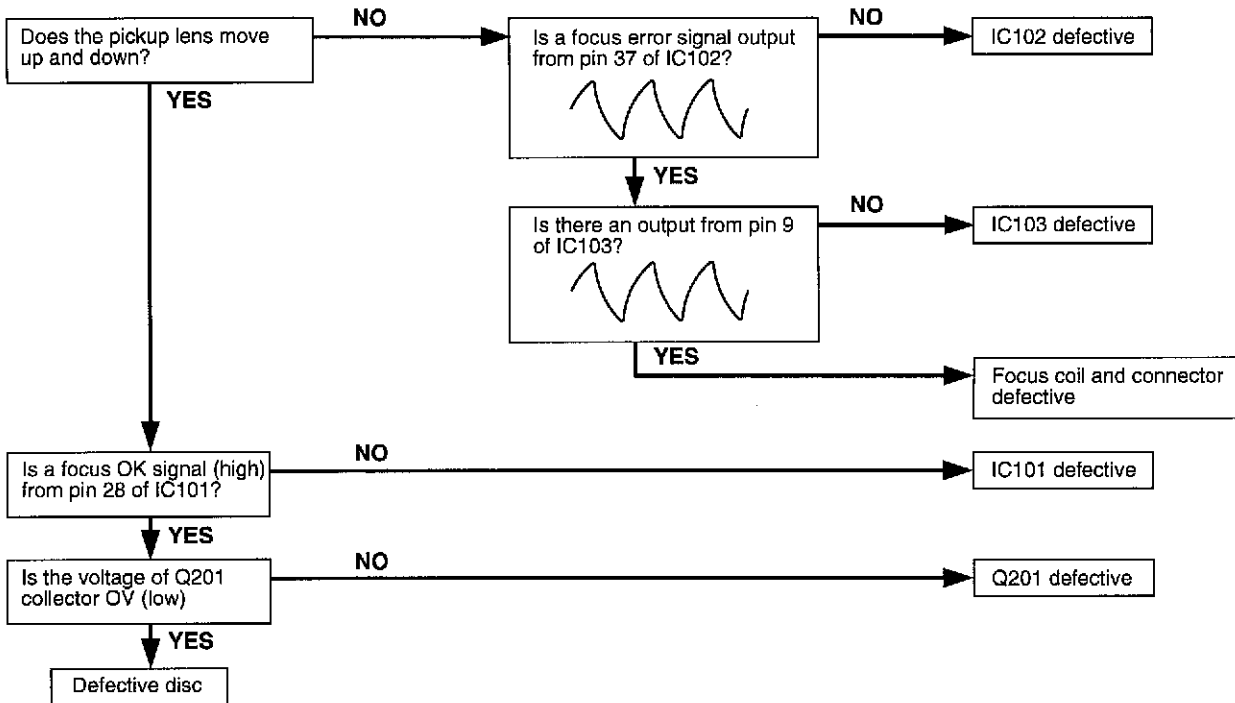

When there is no audio output

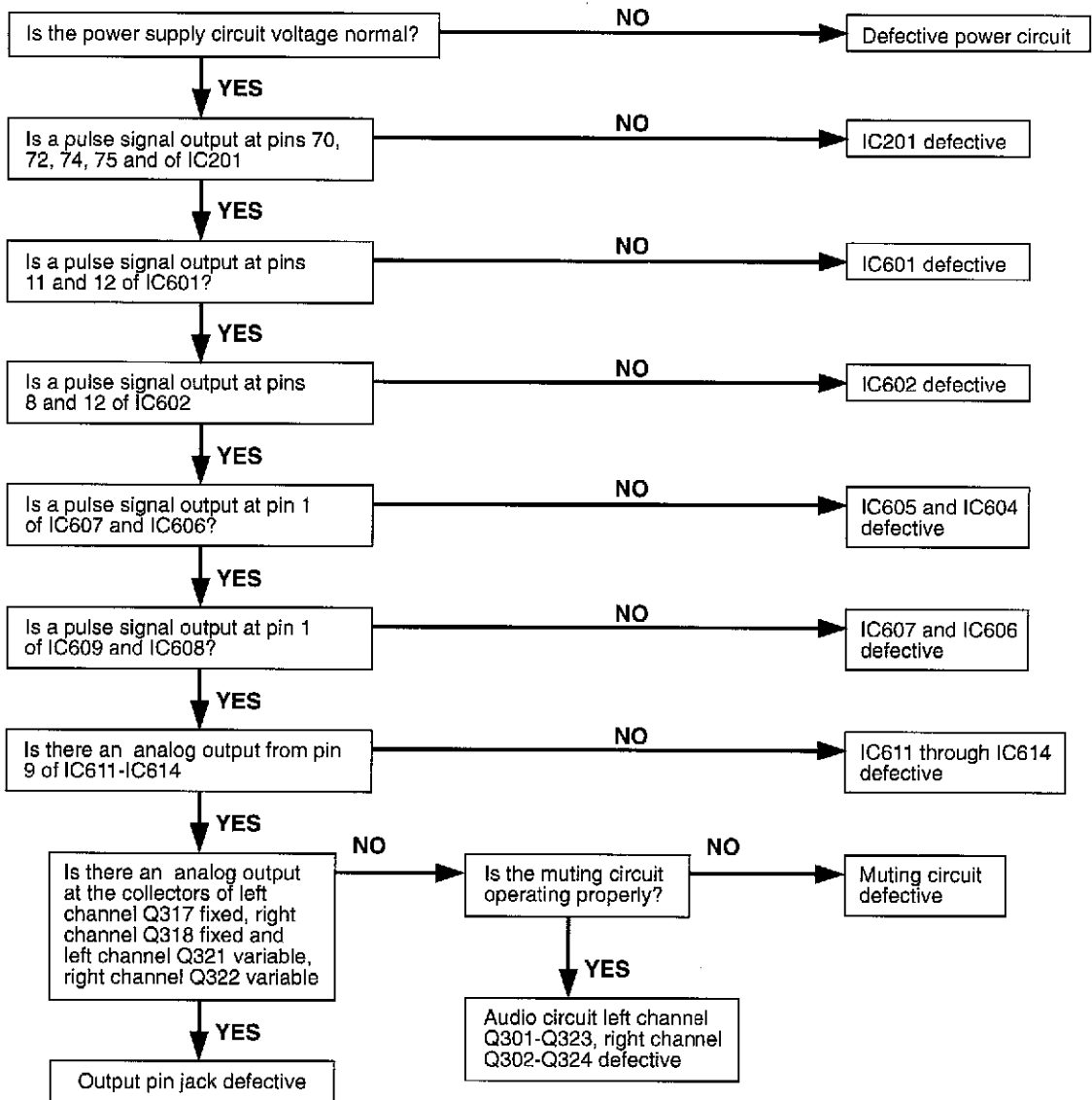

IC NUMBER	TERMINAL NUMBER	PORT NAME	TERMINAL CODE	I/O	OUTLINE OF FUNCTIONS
IC101	1	RFI		I	RF summing amp. input terminal.
	2	RFO		O	RF summing amp. output terminal.
	3	RF-		I	RF summing amp. return input terminal.
	4	P/N		I	Laser diode P/N select terminal.
	5	LD		O	APC LD amp. output terminal.
	6	PD		I	APC PD amp. input terminal.
	7	PD1		I	RF I-V amp. (1) invert input terminal.
	8	PD2		I	RF I-V amp. (2) invert input terminal.
	9	VC		-	GND terminal.
	10	F		I	F I-V amp. invert input terminal.
	11	E		I	E I-V amp. invert input terminal.
	12	EO		O	E I-V amp. output terminal.
	13	EI		I	E I-V amp. return input terminal.
	14	VR		O	DC voltage output terminal.
	15	CC2		I	DEFECT signal input terminal.
	16	CC1		O	DEFECT signal output terminal.
	17	VEE		-	Negative power terminal.
	18	FE BIAS		I	Focus error amp. bias terminal.
	19	FE		O	Focus error amp. output terminal.
	20	TE		O	Tracking error amp. output terminal.
	21	DEFECT		O	DEFECT comparator output terminal.
	22	MIRR		O	MIRR comparator output terminal.
	23	CP		I	MIRR hold capacitor connect terminal.
	24	CB		I	DEFECT hold capacitor connect terminal.
	25	DGND		-	GND terminal.
	26	ASY		I	Auto asymmetry control input terminal.
	27	EFM		O	EFM comparator output terminal.
	28	FOK		O	Focus OK comparator output terminal.
	29	LD ON		I	Laser diode on/off select terminal.
	30	VCC		-	Positive power terminal
IC102	3	TE IN	Pre amp. input	I	Tracking error signal input terminal.
	4	TC IN	Pre amp. input	I	Track cross signal input terminal.
	5	MR	Pre amp. input	I	Mirror detected signal input terminal.
	6	Jump Flag	Mi-com I/O	O	Outputs "H" under jump function.
	8	HF OK	Pre amp. input	I	HF OK signal input terminal.
	9	HFD	Mi-com I/O	O	"1" indicates that MR input is "1" and track servo loop is off (TS OFF, JF, JR).
	10	DATA OUT	Mi-com I/O	O	Inner condition output changed by command modes.
	11	JP1	Mi-com I/O	I	1 track jump control signal. Usually "H".
	12	MSD	Mi-com I/O	I	Serial data input terminal (LSB first, 8-bit data).
	13	MLA	Mi-com I/O	I	Latch signal of serial data from mi-com to servo IC.
	14	MCK	Mi-com I/O	I	Clock signal of serial data from mi-com to servo IC. Receives data on leading edge.
	15	ACLR	Mi-com I/O	I	All clear input (clear inner registers and flip-flops by "L" signal).
	18	Bias	Power supply	O	Vcc/2 bias power supply output when single-pole power supply is used.
	19	COM	Power supply	I	Common terminal. Connect to GND when double-pole power supply is used and to BIAS when single-pole power supply is used.
	20	GND	Power supply	I	GND terminal.
	21	VEE	Power supply	I	Negative power terminal. Connect to GND when single-pole power supply is used.
	22	C*FSR	Focus supply	-	Connect capacitor which determines time constant of focus search waveform.
	23	I-Ref	Power supply	I	Terminal for connecting resistor for setting current value of reference current source.
	24	Vcc	Power supply	I	Positive power terminal.
	25	SS OUT	Slide servo	O	Operation amplifier SS output.
	26	SS -	Slide servo	I	Operation amplifier SS reverse input.
	27	SS +	Slide servo	I	Operation amplifier SS non-reverse input.
	28	TS OUT	Track servo	O	Operation amplifier TA output.
	29	TS -	Track servo	I	Operation amplifier TA reverse input.
	30	TG2	Track servo	-	Track gain select switch TG2 output. Set to open or common level.
	31	TS +	Track servo	I	Operation amplifier TA non-reverse input.
	32	TG1	Track servo	-	Track gain select switch TG1 output. Set to open or common level.
	33	TE OUT	Track servo	O	Operation amplifier TE output.
	34	TE -	Track servo	I	Operation amplifier TE reverse input.
35	FSR IN	Focus servo	I	Focus search voltage level detector input.	
36	FG	Focus servo	-	Focus gain select switch FG output. Set to open or common level.	
37	FS OUT	Focus servo	O	Operation amplifier FA output.	
38	FS -	Focus servo	I	Operation amplifier FA reverse input.	
39	FS +	Focus servo	I	Operation amplifier FA non-reverse input.	

IC NUMBER	TERMINAL NUMBER	PORT NAME	TERMINAL CODE	I/O	OUTLINE OF FUNCTIONS
IC103	1	+VIN 1		I	Positive input terminal 1 for amp. 1.
	2	-VIN 1		I	Negative input terminal 1 for amp. 1.
	3	OUT 1		O	Output terminal 1.
	4	OUT 2		O	Output terminal 2.
	5	-VIN 2		I	Negative input terminal 2 for amp. 2.
	6	+VIN 2		I	Positive input terminal 2 for amp. 2.
	7	+VIN 3		I	Positive input terminal 3 for amp. 3.
	8	-VIN 3		I	Negative input terminal 3 for amp. 3.
	9	OUT 3		O	Output terminal 3.
	10	NC		-	
	11	NC		-	
	12	Vcc		-	Positive power supply.
IC201	1	EMP		O	Emphasis code output. Emphasis = "1"
	2	PWM1		O	Disc motor drive PWM output 1. -
	3	PWM2		O	Disc motor drive PWM output 2. +
	4	DOTX		O	Digital output.
	5	ACRCY		I	Channel status clock input.
	6	TEST1		I	Test mode select input.
	7	DOBSEL		I	Output data bit select.
	8	DASEL1		I	D/A converter interface select input 1.
	9	DASEL2		I	D/A converter interface select input 2.
	10	DASEL3		I	D/A converter interface select input 3.
	11	DASEL4		I	D/A converter interface select input 4.
	12	MSD		I	Microcomputer interface serial data input.
	13	MCK		I	Microcomputer interface shift clock input.
	14	MLA		I	Microcomputer interface data latch clock input.
	15	ACLR		I	Microcomputer interface register clear input.
	16	HFD		I	Play signal absence signal input.
	17	HF		I	Play signal input.
	18	IREF		I	Detection/PLL circuit reference current input.
	19	TLC		O	Slice level control output.
	20	LPF		I/O	PLL loop filter connection terminal.
	21	LOCK/DRD		O	Synchronous/low disc rotate status output.
	22	SYCLK		O	Frame synchronous status output.
	23	VDD2		I	5V power supply used for Detection/PLL circuit analog area only.
	24	DRD		O	Low disc rotate status output.
	25	EFFK		O	EFM frame clock output.
	26	SCINT		O	Subcode Q interrupted signal output.
	27	SQRQ		O	Subcode Q register output.
	28	SQRCK		I	Subcode Q register data shift clock input.
	29	SCOR		O	Subcode synchronous signal output.
	30	CRCF		O	Subcode Q CRC check result output.
	31	SCCK		I	Shift clock input for serial subcode data output.
	32	VSS2		I	GND terminal.
	33	SCOE2		I	Subcode parallel output channel P to S enable input.
	34	SCOE1		I	Subcode parallel output channel T to W enable input.
	35	SBCW		O	Subcode channel W output.
	36	SBCV		O	Subcode channel V output.
	37	SBCU		O	Subcode channel U output.
	38	SBCT		O	Subcode channel T output.
	39	SBCS		O	Subcode channel S output.
	40	SBCR		O	Subcode channel R output.
	41	SBCQ		O	Subcode channel Q output.
	42	SBCP		O	Subcode channel P output.
43	RAS	RT1	O	Row address strobe signal output.	
44	TEST 2	TEST 2	I	Test mode select input.	
45	RDB2	RT2	I/O	External memory data I/O 2.	
46	NC		-		
47		RT3	I/O	External memory data I/O 1.	
48		RT4	I/O	External memory data I/O 4.	
49		RT5	O	Column address strobe signal output.	
50		RT6	I/O	External memory data I/O 3.	
51		RT7	O	Write enable signal output.	
52		RT8	I	External memory address output 7.	
53		RT9	O	External memory address output 1.	
54		RT10	O	External memory address output 2.	

IC NUMBER	TERMINAL NUMBER	PORT NAME	TERMINAL CODE	I/O	OUTLINE OF FUNCTIONS
IC201	55		RT11	O	External memory address output 3.
	56	NC		-	
	57		RT12	O	External memory address output 4.
	58		RT13	O	External memory address output 5.
	59		RT14	O	External memory address output 6.
	60	RT15	RT15	O	External memory address output 0.
	61	EST2		O	Error status 2.
	62	EST1		O	Error status 1.
	63	VDD1		I	5V power supply.
	64	DOFK		O	OSC frame clock output.
	65	F5CK		O	Clock output 44.1kHz.
	66	C846		O	Clock output 8.4672MHz.
	67	C423		O	Clock output 4.2336MHz.
	68	CKSEL		I	1/2 divider input.
	69	DFSEL		O	1/2 divider output.
	70	XI		I	Crystal oscillator input.
	71	XO		O	Crystal oscillator output.
	72	DO1		O	D/A converter serial data output.
	73	VSS1		I	GND terminal.
	74	DSCK		O	D/A converter data shift clock output.
75	LRCK		O	D/A converter left/right clock output.	
76	DQ2		O	Dual D/A converter serial data output.	
77	WDCK		O	D/A converter word clock.	
78	DLRCK		O	D/A converter left/right clock output.	
79	APTL		O	D/A converter deglitch clock L.	
80	APTR		O	D/A converter deglitch clock R.	
IC203	1	VSENCE1			
	2	OUT1		O	Output terminal 1.
	3	-VIN1		I	Negative input 1.
	4	+VIN1		I	Positive input 1.
	5	VEE			Negative power supply.
	6	+VIN2		I	Positive input 2.
	7	-VIN2		I	Negative input 2.
	8	OUT2		O	Output terminal 2.
	9	VSENCE2			
	10	Vcc			Positive power supply.
IC401	1	VCC			Positive power supply.
	2	P65		I/O	
	3	P64		I/O	
	4	P63		I/O	
	5	P62		I/O	
	6	P61		I/O	
	7	P60		I/O	
	8	P27	I/O port	I/O	Disc tray open direction driving output.
	9	P26	I/O port	I/O	Disc tray close direction driving output.
	10	P25	I/O port	I/O	
	11	P24	I/O port	I/O	Serial data output.
	12	P23	I/O port	I/O	Serial data output.
	13	P22	I/O port	I/O	Data latch clock output.
	14	P21	I/O port	I/O	
	15	P20	I/O port	O	
	16	P37	OUT PORT	O	Display output i.
	17	P36	OUT PORT	O	Display output g.
	18	P35	OUT PORT	O	Display output f.
	19	P34	OUT PORT	O	Display output e.
	20	P33	OUT PORT	O	Display output d.
	21	P32	OUT PORT	O	Display output c.
	22	P31	OUT PORT	O	Display output b.
	23	P30	OUT PORT	O	Display output a.
	24	P53			
	25	P52			
	26	CNVSS			Usually connected to VSS.
	27	RESET		I	Reset input.
	28	XIN	CLOCK IN	I	Clock input.
	29	XOUT	CLOCK OUT	O	Clock output.
	30	XCIN	CLOCK IN	I	Serial data input.

IC NUMBER	TERMINAL NUMBER	PORT NAME	TERMINAL CODE	I/O	OUTLINE OF FUNCTIONS
IC401	31	XCOU	CLOCK OUT	O	Clock output.
	32	VSS			Power supply.
	33	∅		O	Timing output.
	34	P57			
	35	P56			
	36	P55			
	37	P54			
	38	VP		I	Pull down voltage input.
	39	P51			
	40	P50			
	41	P17	OUT PORT	O	Laser diode control output.
	42	P16	OUT PORT	O	Display output 7.
	43	P15	OUT PORT	O	Display output 6.
	45	P13	OUT PORT	O	Display output 4.
	46	P12	OUT PORT	O	Display output 3.
	47	P11	OUT PORT	O	Display output 2.
	48	P10	OUT PORT	O	Display output 1.
	49	P07	I/O PORT	I/O	Serial data input.
	50	P06	I/O PORT	I/O	Frame synchronous state output.
	51	P05	I/O PORT	I/O	Low disc rotate state output.
	52	P04	I/O PORT	I/O	Sub-code synchronous signal output.
	53	P03	I/O PORT	I/O	Sub-code Q check.
	54	P02	I/O PORT	I/O	Sub-code channel Q output.
	55	P01	I/O PORT	I/O	Interrupt input.
	56	P00	I/O PORT	I/O	
	57	P47			
	58	P46			
	59	P45			
	60	P44			
	61	P43			
	62	P42			
	63	P41			
64	P40				
IC501	1	OUT1		O	Output terminal 1.
	2	II1		I	Negative input terminal 1 for amp. 1.
	3	IN1		I	Positive input terminal 1 for amp. 1.
	4	V-			Negative power supply.
	5	IN2		I	Positive input terminal 2 for amp. 2.
	6	II2		I	Negative input terminal 2 for amp. 2.
	7	OUT2		O	Output terminal 2.
	8	V+			Positive power supply.
IC601	1				Not used.
	2	XTI		I	Crystal oscillator connection (CD system 16.9344MHz)
	3	XTO		O	Crystal oscillator connection.
	4	CKO		O	Oscillator output clock. The frequency at this pin is the same as the frequency on the XTI pin.
	5	Vss		-	Ground.
	6	NC		-	
	7	DEEM		I	Mode set bit clock (used to set the mode flags and the attenuator register).
	8	MUTE		I	Mode set latch enable (used to set the mode flags and the attenuator register).
	9	RST		I	Device reset.
	11	DOR		O	Right channel data output (OMOD flag = Low : 8fs data output; OMOD flag = High : 4fs data output).
	12	DOL		O	Left channel data output (OMOD flag = Low : 8fs data output; OMOD flag = High : 4fs data output).
	13	WCKO		O	Output word clock.
	14	VDD		-	Positive supply (5V).
	15	BCKO		O	Output data bit clock.
	16	LRCI		I	Input data word clock. LR input data multiplexed clock. CD system at normal : 44.1kHz, at high speed : 88.2kHz.
	17	BCKI		I	Input data bit clock.
	18	DIN		I	Input data.
	IC602	1	1A		
2		1Y			Out.
3		2A			In.
4		2Y			Out.
5		3A			In.

IC NUMBER	TERMINAL NUMBER	PORT NAME	TERMINAL CODE	I/O	OUTLINE OF FUNCTIONS
IC602	6	3Y			Output.
	7	GND			Ground.
	8	4Y			Out.
	9	RA			In.
	10	5Y			Out.
	11	5A			In.
	12	6Y			Out.
	13	6A			In.
	14	Vcc			Supply voltage.
IC603	1	A			Serial input.
	2	B			Serial input.
	3	QA			Output.
	4	QB			Output.
	5	QC			Output.
	6	QD			Output.
	7	GND			Ground.
	8	CP			Clock pulse.
	9	MR			Master reset clear.
	10	QE			Output.
	11	QF			Output.
	12	QG			Output.
	13	QH			Output.
		14	Vcc		
IC611 through IC614	1	-Vs		-	Negative analog power supply.
	2	DIG GND		-	Digital ground.
	3	+VI		-	Positive logic power supply.
	4	NC		-	
	5	CLK		I	Clock input.
	6	LEC		I	Latch enable control input.
	7	DATA		I	Data input.
	8	-VI		-	Negative logic power supply.
	9	VOUT		O	Voltage output.
	10	RF		I	Feedback resistor.
	11	SJ		I	Summing junction.
	12	ANA GND		-	Analog ground.
	13	IOUT		O	Current output.
	14	MSB ADJ		-	MSB adjustment terminal.
	15	V POT		-	Potentiometer terminal.
	16	+Vcc		-	Positive analog power terminal.
IC801	1	1Y		O	Output terminal 1.
	2	1A		I	Input terminal 1.
	3	1B		I	Input terminal 1.
	4	2Y		O	Output terminal 2.
	5	2A		I	Input terminal 2.
	6	2B		I	Input terminal 2.
	7	GND			Ground terminal.
	8	3A		I	Input terminal 3.
	9	3B		I	Input terminal 3.
	10	3Y		O	Output terminal 3.
	11	4A		I	Input terminal 4.
	12	4B		I	Input terminal 4.
	13	4Y		O	Output terminal 4.
		14	VCC		

CIRCUIT DESCRIPTION

1. APC CIRCUIT

A semiconductor laser is used as the light source for the optical pickup. As the output from the semiconductor laser changes radically with changes in temperature, a circuit must be provided to stabilize this output. For this purpose, a monitor diode which detects the optical output of the laser diode is used in the semiconductor laser.

As the laser diode emits light from its bonded surface, light is emitted both in front and behind. The light emitted behind is monitored with the monitor diode installed on its rear surface, and the optical output is thus controlled. The light emitted in front becomes the light source for the pickup.

Fig. 1 shows the APC circuit.

When the temperature rises and the optical output decreases, the monitor diode current (I_S) decreases, the electric potential of IC101 pin 5 rises, the base current of the driving transistor increases, and the laser diode current increases. This causes the reduced optical output to return to its former level.

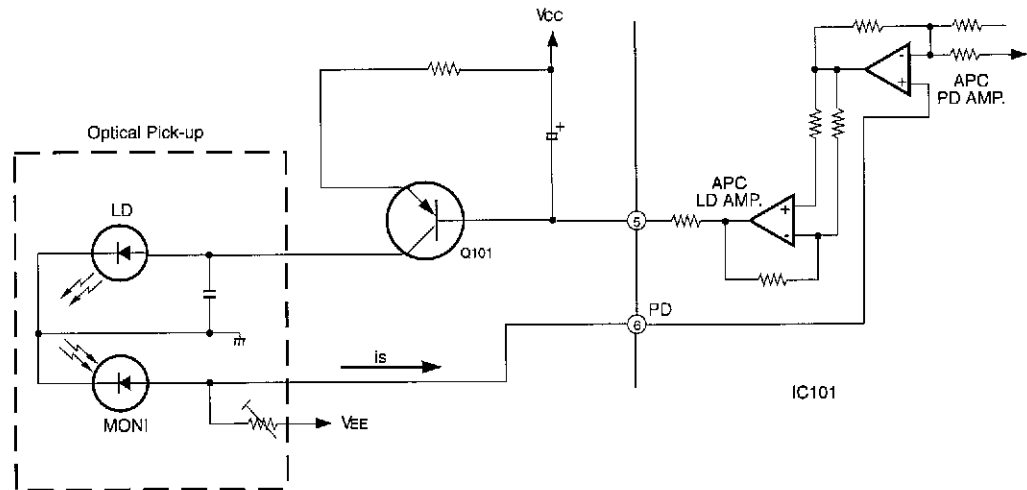

Fig. 1

2. FOCUS SERVO

2-1. Optical Pickup

This set employs a three-beam optical pickup comprised of six division photodiodes, A through F as shown in Fig. 2. The four photodiodes (A through D) at the center provide focus error detection by using their property to allow the beam to focus into a round image only at a certain point.

The sums of outputs from diagonal two elements of four division photodiodes (A+C and B+D) are compared by the differential amplifier in IC101 to detect the shape of the beam image.

The remaining two diodes (E and F) provide tracking error detection by means of sub-beam spots.

2-2. Focus error detecting operation

The reflected laser beam from a disc is polarized 90 with the beam-splitter and sent to the cylindrical lens. The beam passed through this cylindrical lens is then sent to the four division photodiodes and focuses into an image whose shape varies with the distance between the disc and the objective lens. Such change in the beam shape causes the current flowing from photodiodes to vary.

Shown in Fig. 3 is the principle of the focus error detection.

The currents from the photodiodes (A+C and B+D) are applied to pins 7 and 8 of IC101 and converted to voltage by RF 1-V amplifiers (1) and (2) included in IC101.

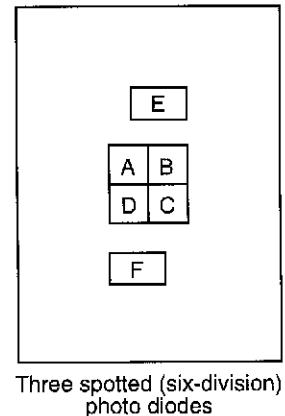

Three spotted (six-division) photo diodes

Fig. 2

Fig. 3

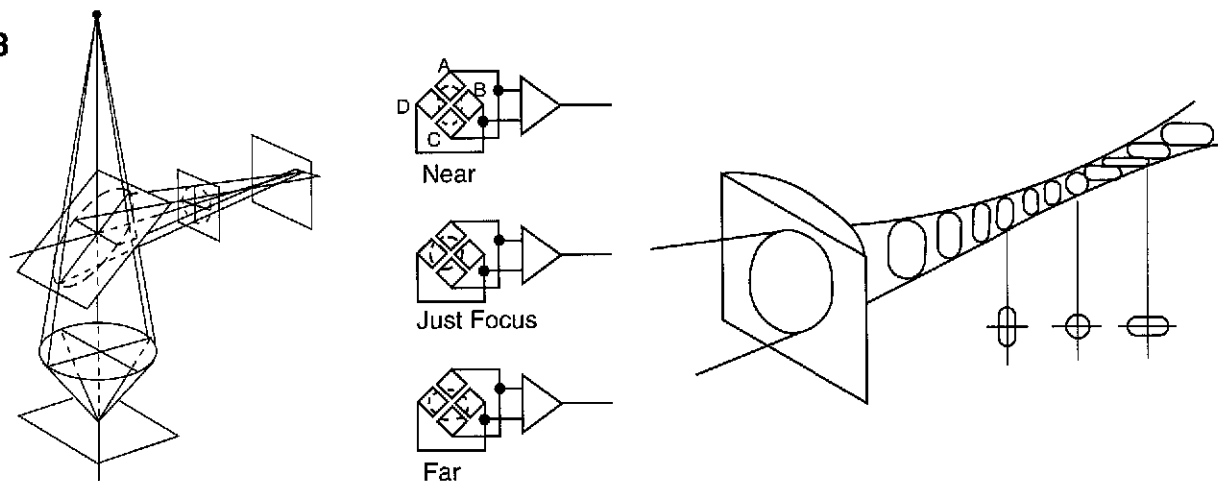

2-3. Focus servo control operation

The focus error signal, after being converted to voltage by the RF 1-V amplifier, is transmitted to the operation amplifier in the IC and output from pin 19. When the disc to objective lens distance is in just focus, the beam forms a true round. In this state, the beams applied to four elements in four division photodiodes become equal and thus the output provided then is 0 (zero). When the disc to objective lens distance is too close (near focus), the beam is reflected divergently to form an oval in crosswise direction. In this state the outputs provided from photodiodes A and C are higher than those from B and D, resulting in negative (-) output voltage. On the other hand, when the distance is too far (far focus), the beam is reflected convergently to form an oval in longitudinal direction. Then the outputs from photodiodes B and D are higher, resulting in positive (+) output.

The output voltage (focus error signal) from pin 19 of IC-101 passes through IC-102, in from pin 39 and out from pin 37, and IC103, in from pin 7 out from pin 9 as shown in Fig. 4. It is amplified in each IC and fed to the focus coil which then drives the objective lens of the pickup.

Fig. 4

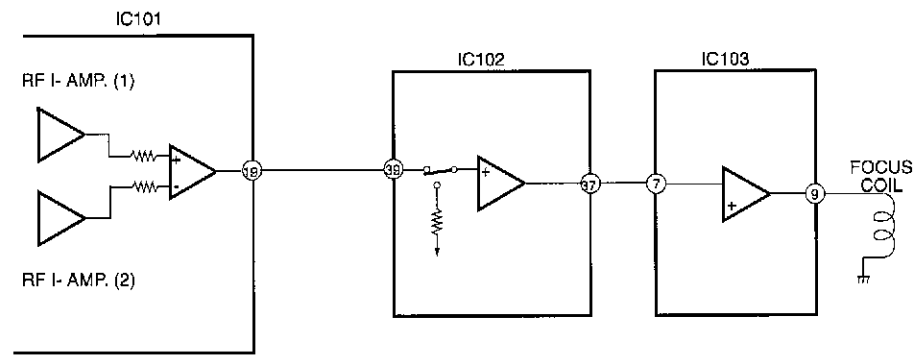

2-4. Tracking error detection

Fig. 5 shows the principle of the tracking error detection system which employs the three beam system.

The laser beam is divided into the main beam and two sub-beams by diffraction grating and they are arranged on one line. The center line connecting these three beams has a slight offset angle against the main beam. The main beam is received by photodiodes A, B, C and D and two sub-beams by E and F respectively.

Fig. F-A shows the on-track state. As both auxiliary beams 1 and 2 are slightly on the track in this state, the outputs of photodiodes E and F are equal and the tracking signal is 0 (zero). When the track is shifted to the left (Fig. 5-B), the auxiliary beam 1 is off the pit. This allows more light to be received by photodiode E, resulting in positive (+) tracking signal output. On the other hand, when the track is shifted to the right (Fig. 5-C), the amount of light received by the photodiode F increases, resulting in negative (-) tracking signal output. And these extreme signals are detected as tracking error signals.

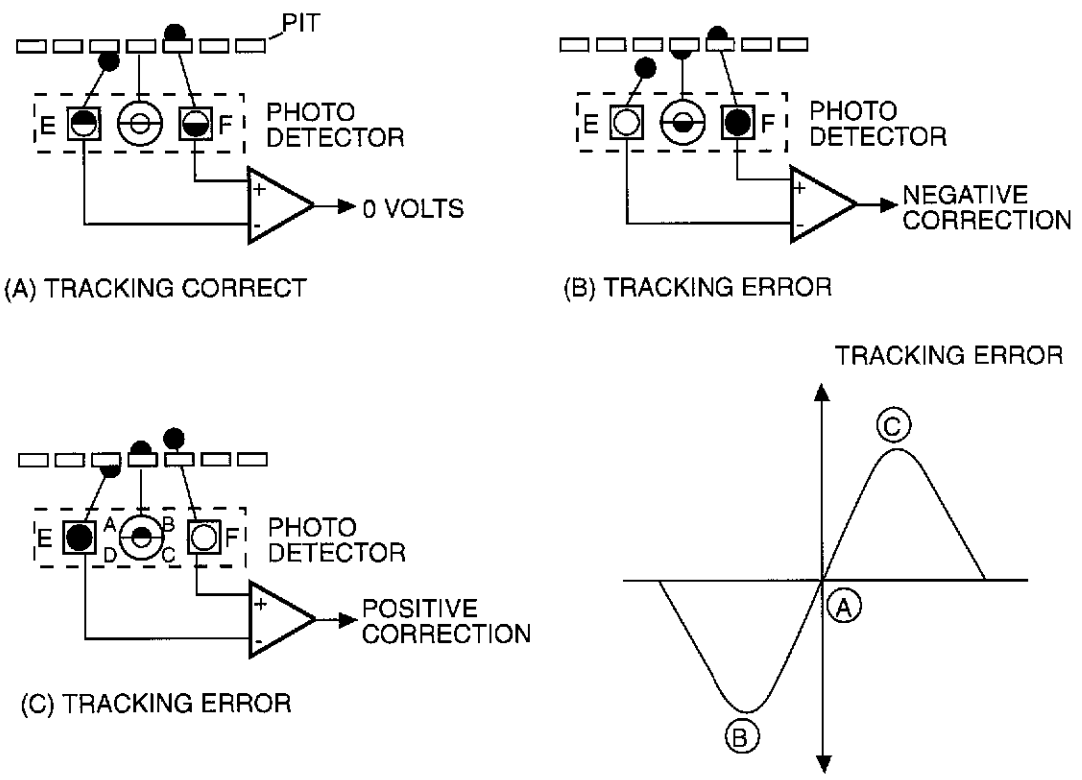
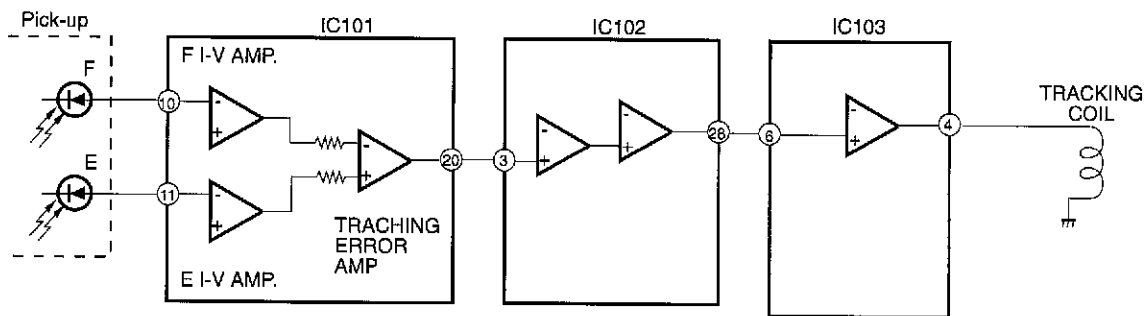

Fig. 5

2-5. Tracking servo control operation

When a tracking error signal is detected by photodiodes E and F, it is fed to pins 11 and 10 of IC101 respectively as shown in Fig. 6. In IC101, the signal is converted into voltage by the E I-V amplifier and F I-V amplifier, transmitted to the tracking error amplifier and output through pin 20. While it passes through IC102, in from pin 3 and out from pin 28, and IC103, in from pin 6 and out from 4, it is amplified in each IC and sent to the tracking coil to adjust pickup so that the amount of track shift is reduced as closely to none as possible.

Fig. 6



3. REGENERATIVE CIRCUIT

3-1. RF circuit

The currents from photodiodes (a, b, c and d) are fed to IC101 through pins 7 and 8 and converted to voltage by RF I-V amplifiers (1) and (2) respectively there, added by the RF summing amplifier and output from pin 2 as a signal. As it is sent to pin 17 of IC201, it can be checked at the test point (TP202) provided on its way by means of the eye pattern check (as shown by Fig. 7).

Fig. 7

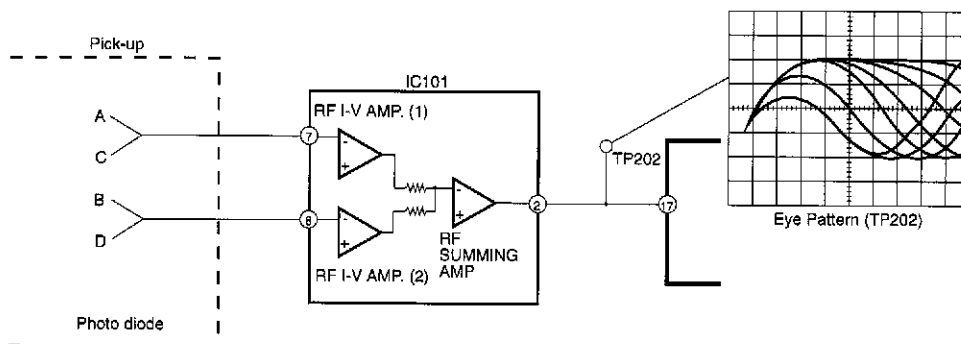

3-2. EFM demodulation, error correction, serial/parallel conversion

EFM demodulation, error correction, and serial/parallel conversion are performed by the internal circuitry of IC201. The eye-pattern signals from pin 2 of IC101 are sent to pin 17 of IC201, then demodulated from 14 bits to 8 bits by EFM readjustment. At the same time any error, if found, is corrected (CIRC) and the signals are sent to the D/A converter interface. After that, they are output from pins 1, 15, 70, 72, 74 and 75 of IC201 and fed to the RLS (Real -Time Linear Smoothing) module (as shown by Fig. 8).

Fig. 8

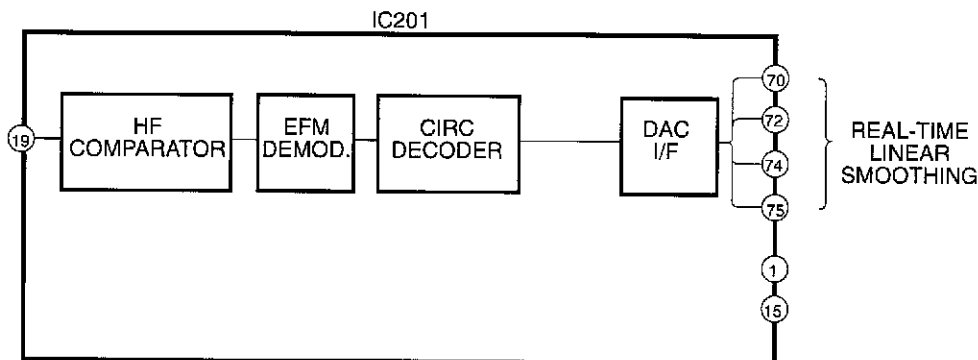

4. REAL-TIME SMOOTHING MODULE

The first stage in the RLS module is the 8 fs digital filter, IC601 (SM5840CP). IC601 also provides the de-emphasis characteristics when needed. The output of IC601 drives the IC602 Hex Inverter and the IC603 8-bit shift register. IC602 and IC 603 drives IC605, IC607 and IC609 (for the left chan) and IC604, IC606 and IC 608 (for the right chan) .The signals from IC605 drives IC611 directly, and passes through IC607 and IC609 before driving IC613. This results in the timing of the signal to pin 7 of IC611 being ahead of the signal to pin 7 of IC613. In the same way, the timing of the signal to pin 7 of IC612 is ahead of the signal to pin 7 of IC614. IC611, IC612, IC613 and IC614 are 18 bit linear D/A converters operating on the R-2 R, or ResistorLadder, Principle. The signals from pin 10 of IC611, IC612, IC613 and IC614 are sent to the Comparator/Integrator and Summing Amplifier (as shown in Fig. 9).

THE RLS SYSTEM (BLOCK DIAGRAM)

Fig. 9

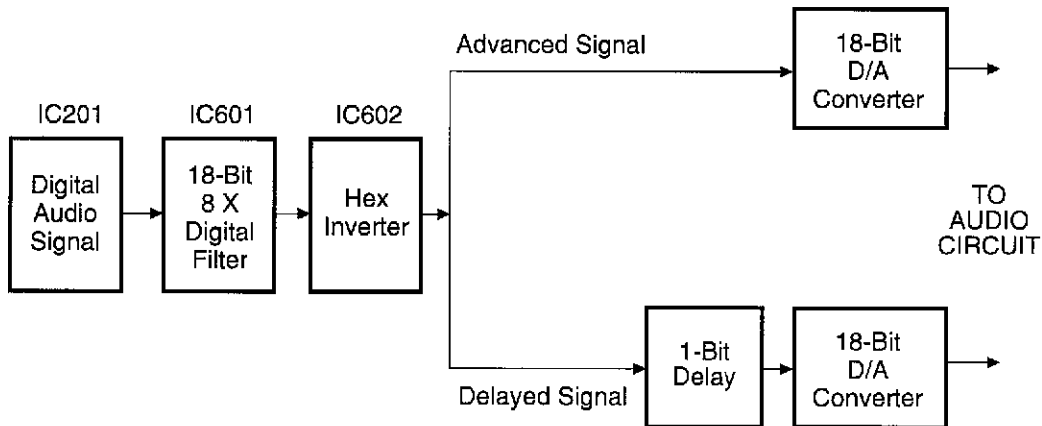

5. AUDIO CIRCUIT

5-1. Comparator/Integrator and Summing Amplifier.

Dual-Differential circuits comprising of Q301, Q303, Q305, Q307, Q309 and Q311 with capacitor C309 ,smoothes out the time difference between IC611 and IC613. The signal is then fed through R329 to the final buffer circuit, Q313 and Q315 (for the left channel). Also Dual-Differential circuits comprising of Q302, Q304, Q306, Q308, Q310 ,and Q312 with capacitor C310, smoothes out the time difference between IC612 and IC614. The signal is then fed through R330 to the final buffer circuit,Q314 and Q316 (for the right channel).

5-2. Output Amplifier

The fixed left output jacks are driven by an amplifier comprised of Q317 and Q319. The variable left output jacks are driven by an amplifier comprised of Q321 and Q323. Also Muting is provided by Q331, Q332, Q333 and Q334. The fixed right output jacks are driven by an amplifier comprised of Q318 and Q320. The variable right output jacks are driven by an amplifier comprised of Q322 and Q324. Also Muting is provided by Q335, Q336, Q337 and Q338 (as shown by Fig. 10).

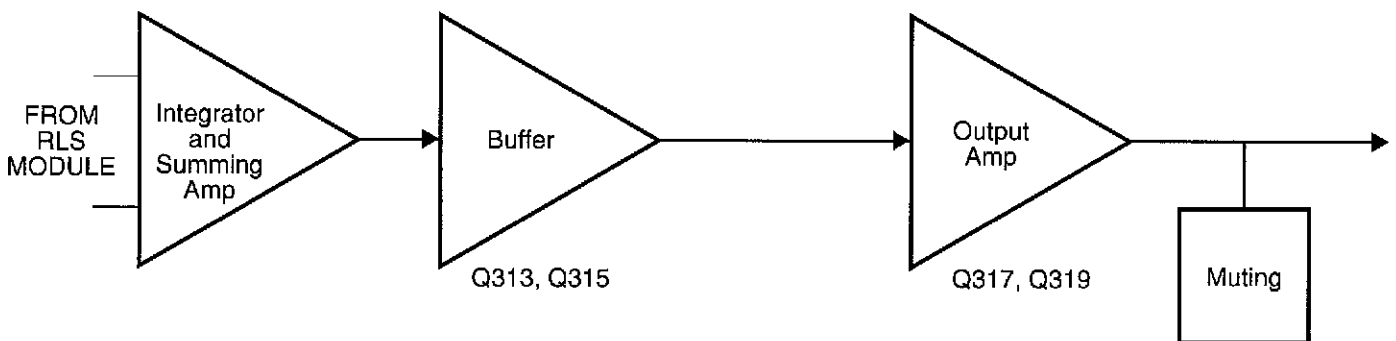
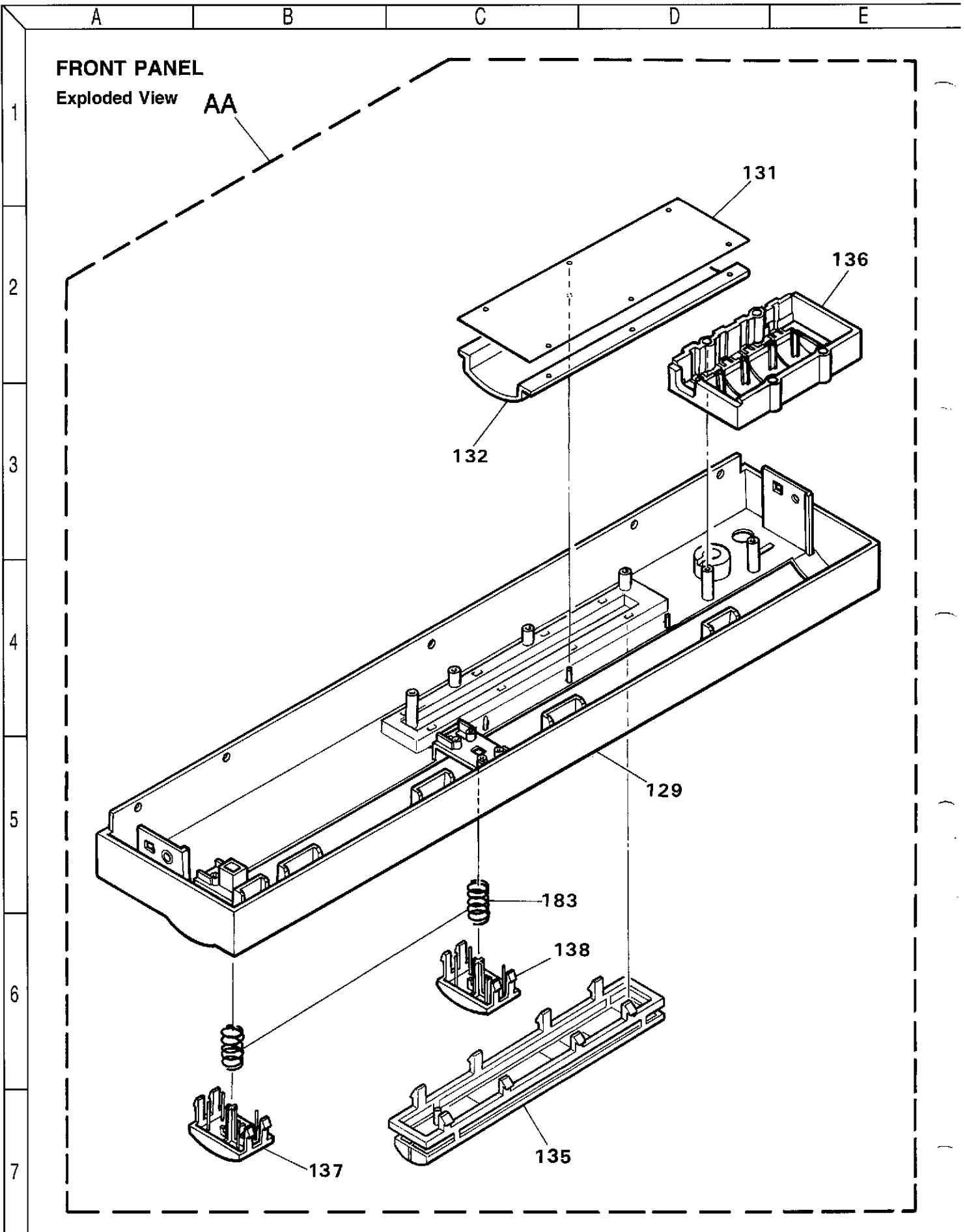

Fig. 10



A

B

C

D

E

GENERAL UNIT

Exploded View

1

2

3

4

5

6

7

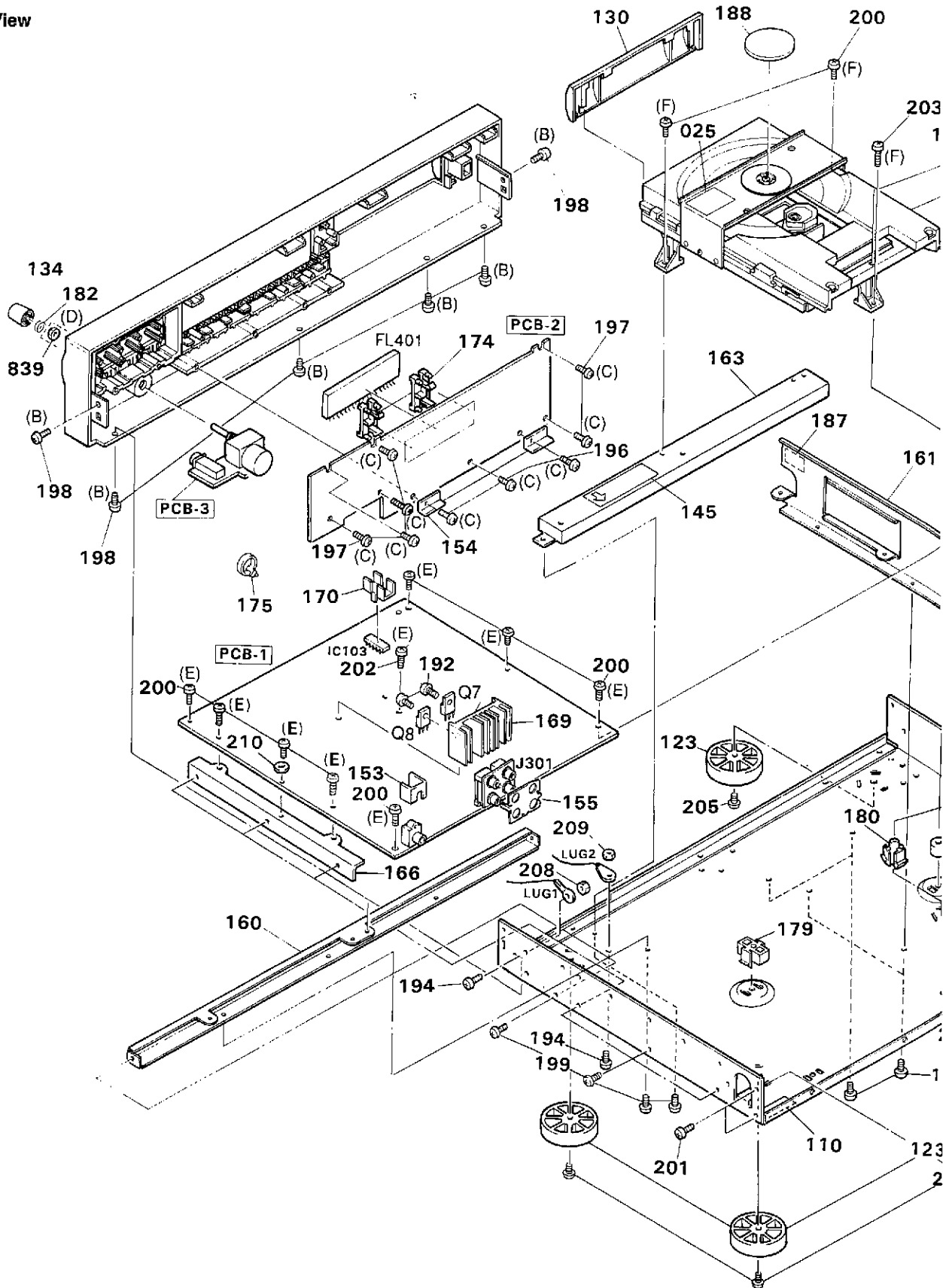

F

G

H

J

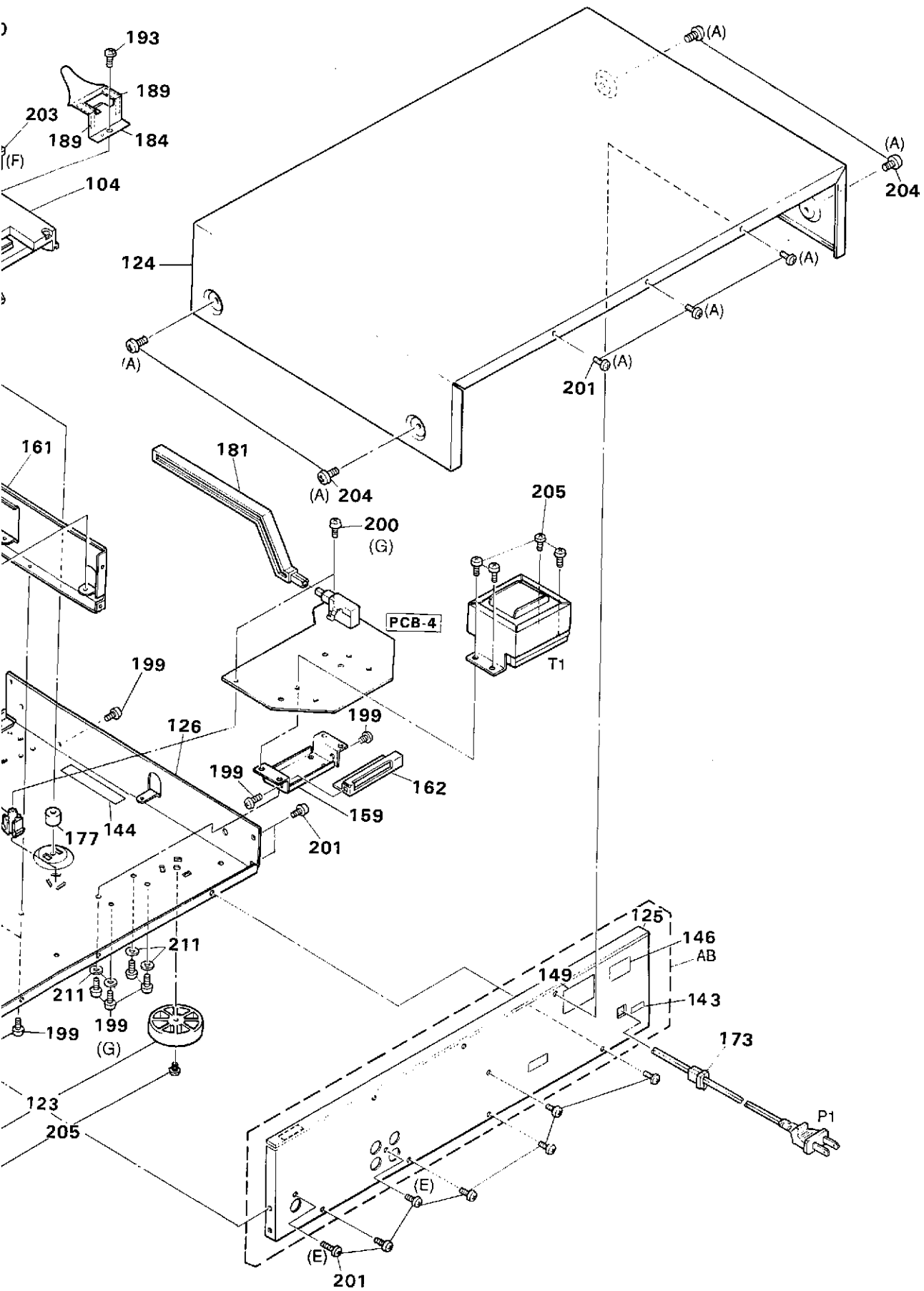

CD MECHANISM
Exploded View

1
2
3
4
5
6
7

A B C D E

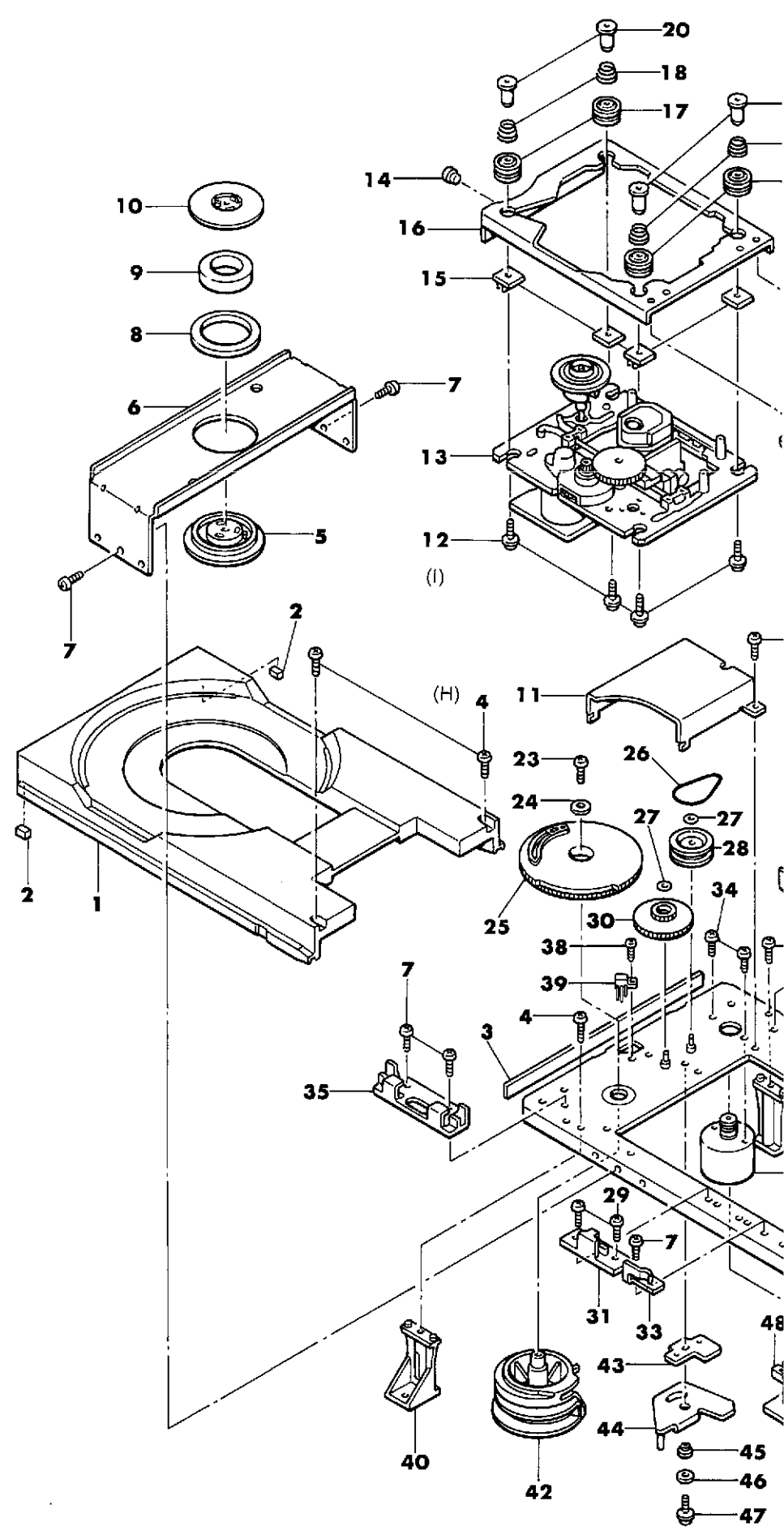

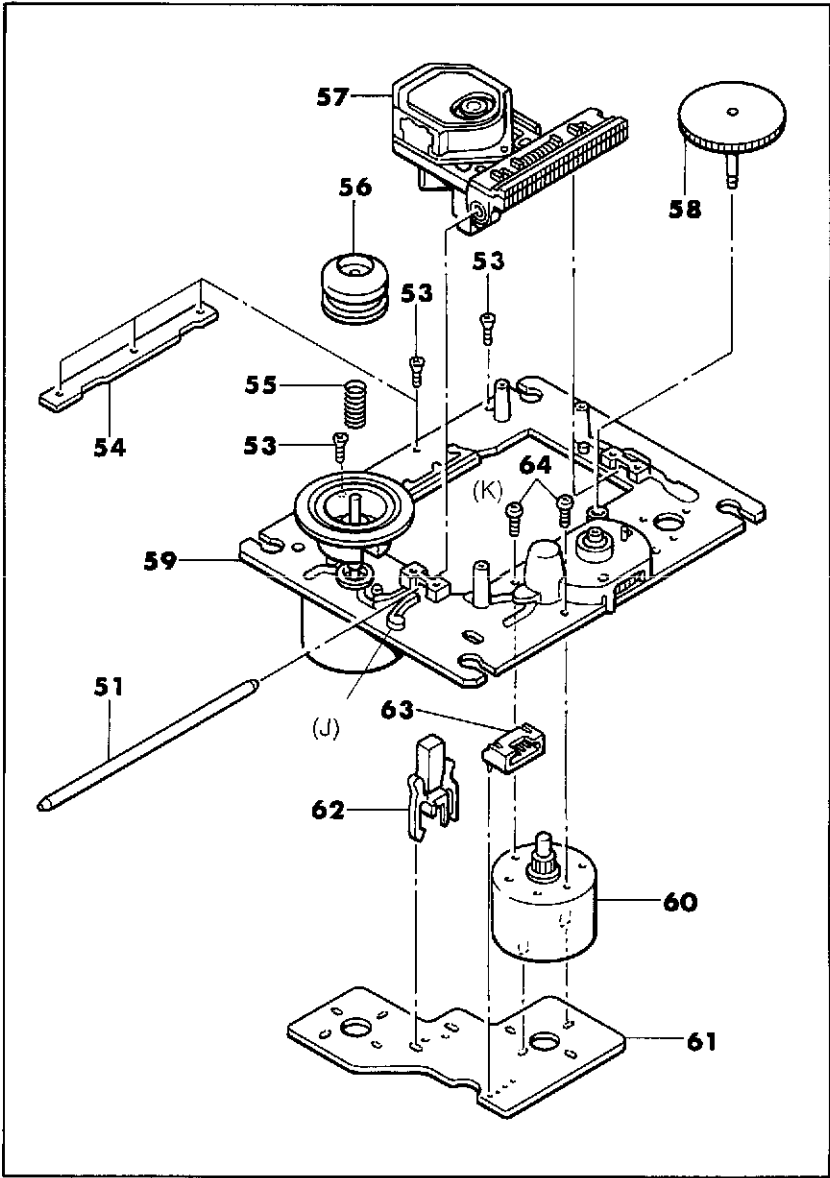
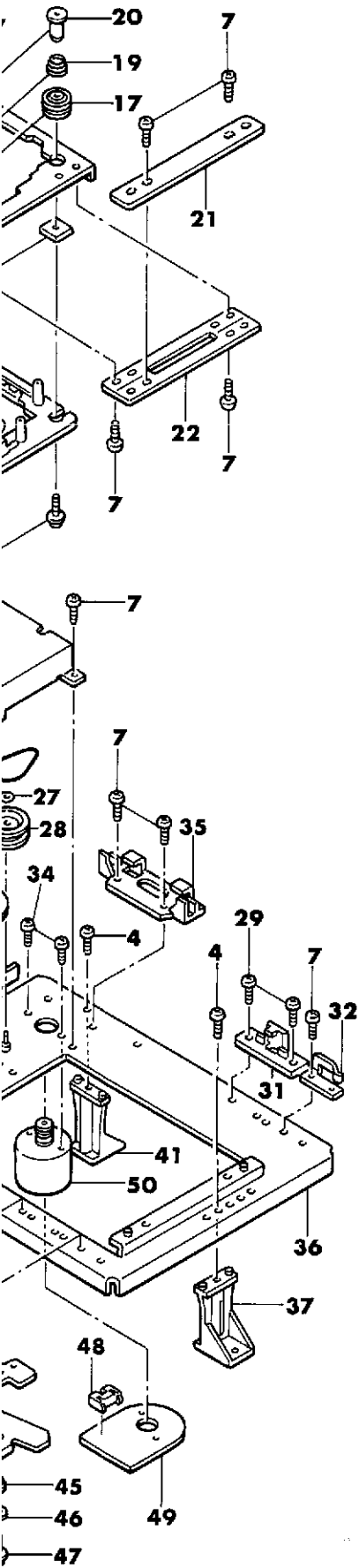

GENERAL UNIT PARTS LIST

Ref. No. Part No.		Description	REF. NO.	PART NO.	DESCRIPTION
AA	A442-HD7625A	FRONT PANEL ASSEMBLY G	179	2360-7018	SPECIAL BOSS, MAIN PCB
AA	A442-HD7625C	FRONT PANEL ASSEMBLY GP	180	2360-7022	SPECIAL BOSS, POWER SUPPLY PCB
AB	A424-HD7625B	CABINET BACK ASSEMBLY	181	2601-7187	SHAFT, POWER SWITCH
025	1756-11802	LABEL	182	2651-110541	SPRING, VOLUME KNOB
104	A 3119-02401	CD MECHA ASSEMBLY	183	2651-2101732	SPRING, PUSH BUTTON (X2)
110	1117-78	SERIAL LABEL, SET	184	2652-124	LEAF SPRING, MECHA REAR
123	1319-02301	LEG (X4)	187	2111-1197	FELT, CD MECHA SIDE
124	1414-14601	CABINET TOP	188	2111-1422	FELT, MECHA
125	1424-33024	COBINET BACK	189	2111-11771	FELT, LEAF SPRING (X2)
126	1424-29603	CABINET BOTTOM	192	2327-R0130082	SCREW, BND+ (3x8 mm) (X2)
129	1442-28703	FRONT PANEL G	193	2342-301046	SCREW, PAN T+(3x10 mm)
129	1442-28704	FRONT PANEL GB	194	2327-R0130062	SCREW, BND+ (3x6 mm) (X2)
130	1452-08302	LID G	196	2343-301021	SCREW, GSK T+ (3x10 mm) (X3)
130	1452-08301	LID GB	197	2347-R0126082	SCREW, BND T+ (2.6x8 mm) (X6)
131	1511-19803	PLATE, FL FILTER	198	2347-R0130064	SCREW, BND T+ (3x6 mm) (X6)
132	1532-17502	WINDOW, FRONT	199	2347-R0130082	SCREW, BND T+ (3x8 mm) (X18)
134	1632-19803	ROTARY KNOB, VOLUME G	200	2347-R0130082	SCREW, BND T+ (3x8 mm) (X12)
134	1632-19801	ROTARY KNOB, VOLUME GB	201	2347-R0130084	SCREW, BND T+ (3x8 mm) (X14)
135	1662-68301	PUSH BUTTON, CONTROL/TRACK/ SELECTION G	202	2347-R0130142	SCREW, BND T+ (3x14 mm)
135	1662-68302	PUSH BUTTON, CONTROL/TRACK/ SELECTION GB	203	2347-R0130162	SCREW, BND T+ (3x16 mm)
136	1662-52202	PUSH BUTTON, FUNCTION G	204	2347-R0140084	SCREW, BND T+ (4x8 mm) (X4)
136	1662-52201	PUSH BUTTON, FUNCTION GB	205	2347-R0140102	SCREW, BND T+ (4x10 mm) (X8)
137	1662-52003	PUSH BUTTON, POWER G	208	2446-301Z9	NUT, HET
137	1662-52001	PUSH BUTTON, POWER GB	209	2440-7016	SPECIAL NUT, EARTH
138	1662-52004	PUSH BUTTON, OPEN/CLOSE G	210	2411-3021	PLAIN WASHER
138	1662-52002	PUSH BUTTON, OPEN/CLOSE GB	211	2401-035	METAL WASHER (X4)
143	1341-568	NAME PLATE, PRODUCTION DATE BR	839	2440-62	SPECIAL NUT
144	1756-03305	LABEL, LASER CAUTION			
145	1756-12101	LABEL, LASER CAUTION			
149	1756-11801	LABEL, LASER WARNING LABEL			
153	2216-7203	SHIELD PLATE, COAXIAL JACK			
154	2216-7187	SHIELD PLATE, FRONT PCB (X2)			
155	2216-7189	SHIELD PLATE, RCA PIN JACK			
159	2219-8262	METAL FITTG, TRANS			
160	2219-8263	METAL FITTG, CHASSIS SIDE			
161	2219-8264	METAL FITTG, CHASSIS TOP			
162	2219-8282	METAL FITTG, TRANS			
163	2219-8290	METAL FITTG, MECHA			
166	2219-8377	METAL FITTG, MAIN PCB			
169	2222-7215	HEAT SINK, Q7, 8			
170	2222-7264	HEAT SINK, IC103			
173	2240-364	HOLDER, AC CORD			
174	2240-7387	HOLDER, FL REAR (X2)			
175	2240-R0101	HOLDER, WIRING (X9)			
177	2363-501725	PIPE BOSS, MECHA			

CD MECHANISM PARTS LIST

REF. NO. PART NO.

DESCRIPTION

Ref. No.	Part No.	Description	Ref. No.	Part No.	Description
1	2-642-156-(02)	TRAY (SP)	49	1-624-793-(21)	PC BOARD, MOTOR
2	2-642-125-(01)	DAMPER (X2)	50	X-2641-336-(1)	MOTOR ASSY (RP)
3	2-642-157-(03)	TAPE, FRONT	51	4-917-565-(01)	SHAFT (S), SLED
4	7-685-547-(19)	SCREW +BTP (3X10mm) (X5)	53	2-641-386-(01)	SCREW (2x5mm), TAPPING (S) (X3)
5	2-642-181-(02)	PULLEY (AU), CHUCKING	54	2-625-625-(01)	REINFORCEMENT (S)
6	2-642-165-(01)	CHASSIS (S), CHUCK	55	2-625-191-(01)	SPRING (S), COMPRESSION
7	7-685-862-(01)	SCREW +BVTT (2.6x6mm) (X13)	56	2-625-187-(01)	RING (LO) (S), CENTER
8	2-642-439-(01)	DAMPER, YOKE	57	8-848-127-(31)	PICK UP KSS-210A (S) (RP)
9	1-452-493-(21)	MAGNET	58	2-625-188-(02)	gear (a) (s)
10	2-642-175-(01)	YOKE (SP), CHUCKING	59	X-2625-317-(1)	CHASSIS ASSY (MT) N, TT
11	2-642-149-(02)	COVER (SP), GEAR	60	X-2625-365-(1)	GEAR ASSY (MT), MOTOR
12	2-642-142-(01)	SCREW, WASHER (X4)	61	1-636-788-(13)	PC BOARD, MOTOR (4P) (S)
13	KSM-2101AAM	DRIVE UNIT	62	1-572-085-(12)	SWITCH, LEAF
14	2-642-169-(02)	ROLLER (SP)	63	1-564-720-(11)	PIN, CONNECTOR 4P
15	2-642-159-(01)	PLATE (T) (SP) (X4)	64	7-621-255-(15)	SCREW +P(2x3mm) (X2)
16	X-2642-105-(2)	CHASSIS ASSY (SP), SUB			
17	2-642-158-(01)	INSULATOR (C) (X4)			
18	2-642-139-(02)	SPRING (A) (X2)			
19	2-642-137-(02)	SPRING (B) (X2)			
20	2-642-160-(02)	SHAFT (T) (SP) (X4)			
21	2-642-170-(01)	RETAINER (SP), HINGE			
22	2-642-164-(01)	HINGE (SP)			
23	7-685-535-(19)	SCREW +BTP (2.6x10mm)			
24	4-812-554-(01)	WASHER			
25	2-642-154-(03)	GEAR(SP), DRIVE			
26	3-653-387-(01)	BELT, LM			
27	3-558-708-(21)	WASHER, STOPPER (X2)			
28	4-913-731-(01)	PULLEY, LOADING			
29	7-685-781-(01)	SCREW +PTT (2X4mm) (X4)			
30	2-642-148-(01)	GEAR (SP), MIDWAY			
31	2-642-162-(03)	HOLDER (REAR) (SP), TRAY (X2)			
32	2-642-147-(02)	GUIDE (LEFT) (SP), TRAY			
33	2-642-146-(02)	GUIDE (RIGHT) (SP), TRAY			
34	7-621-775-(00)	SCREW +B (2.6x3mm) (X2)			
35	2-642-161-(01)	HOLDER (FRONT) (SP), TRAY (X2)			
36	X-2642-106-(2)	CHASSIS ASSY (SP), MAIN			
37	2-642-512-(01)	BOSS (REAR)			
38	7-685-851-(01)	SCREW +BVTT (2x4mm)			
39	1-572-052-(11)	SWITCH, LEAF			
40	2-642-510-(01)	BOSS (RIGHT)			
41	2-642-511-(01)	BOSS (LEFT)			
42	2-642-153-(01)	GAM (SP), CONTROL			
43	2-643-173-(01)	PLATE (SP), LINK			
44	X-2642-109-(1)	LINK ASSY (AU), STOPPER			
45	2-642-133-(02)	BOSS			
46	2-642-172-(01)	SPACER (SP)			
47	7-682-902-(31)	SCREW (2.6x8mm) STPWH			
48	1-564-721-(11)	PIN, CONNECTOR 5P			

ELECTRICAL PARTS LIST

PCB-1 MAIN P.C. BOARD

CAPACITORS

				Ser. No.	Ref. No.	Part No.	Description
511	C12	5345-477C0962	CAP, MINI ELE 470μ/16V	661	C215	5345-107D0962	CAP, MINI ELE 100μ/25V
511	C13	5345-477C0962	CAP, MINI ELE 470μ/16V	566	C301	5345-227C0962	CAP, MINI ELE 220μ/16V
509	C14	5345-228D0962	CAP, MINI ELE 2200μ/25V	566	C302	5345-227C0962	CAP, MINI ELE 220μ/16V
509	C15	5345-228D0962	CAP, MINI ELE 2200μ/25V	566	C303	5345-227C0962	CAP, MINI ELE 220μ/16V
512	C18	5345-227C0962	CAP, MINI ELE 220μ/16V	566	C304	5345-227C0962	CAP, MINI ELE 220μ/16V
512	C19	5345-227C0962	CAP, MINI ELE 220μ/16V	566	C305	5345-227C0962	CAP, MINI ELE 220μ/16V
510	C20	5345-108C0962	CAP, MINI ELE 1000μ/16V	566	C306	5345-227C0962	CAP, MINI ELE 220μ/16V
510	C21	5345-108C0962	CAP, MINI ELE 1000μ/16V	566	C307	5345-227C0962	CAP, MINI ELE 220μ/16V
513	C22	5345-107D0962	CAP, MINI ELE 100μ/25V	566	C308	5345-227C0962	CAP, MINI ELE 220μ/16V
513	C23	5345-107D0962	CAP, MINI ELE 100μ/25V	569	C309	5359-1025851	CAP, PPP 1000P
514	C24	5345-226F0962	CAP, MINI ELE 22μ/50V	569	C310	5359-1025851	CAP, PPP 1000P
514	C25	5345-226F0962	CAP, MINI ELE 22μ/50V	568	C311	5359-1035851	CAP, PPP .01μ
538	C31	5354-104593	CAP, MYL .1μ	568	C312	5359-1035851	CAP, PPP .01μ
779	C52	5345-226D0962	CAP, MINI ELE 22μ/25V	570	C313	5359-8215851	CAP, PPP 820P
778	C53	5345-107B0962	CAP, MINI ELE 100μ/10V	570	C314	5359-8215851	CAP, PPP 820P
780	C54	5345-106F0962	CAP, MINI ELE 10μ/50V	570	C315	5359-8215851	CAP, PPP 820P
780	C55	5345-106F0962	CAP, MINI ELE 10μ/50V	570	C316	5359-8215851	CAP, PPP 820P
782	C56	5354-104593	CAP, MYL .1μ	567	C317	5345-S06DM227	CAP, MINI ELE 220μ/25V
781	C58	5345-105F0962	CAP, MINI ELE 1μ/50V	567	C318	5345-S06DM227	CAP, MINI ELE 220μ/25V
780	C59	5345-106F0962	CAP, MINI ELE 10μ/50V	567	C319	5345-S06DM227	CAP, MINI ELE 220μ/25V
663	C101	5345-107B0962	CAP, MINI ELE 100μ/10V	567	C320	5345-S06DM227	CAP, MINI ELE 220μ/25V
684	C102	5361-100DCH	CAP, CER 10P	803	C501	5345-476D0962	CAP, MINI ELE 47μ/25V
684	C103	5361-100DCH	CAP, CER 10P	803	C502	5345-476D0962	CAP, MINI ELE 47μ/25V
684	C104	5361-100DCH	CAP, CER 10P	600	C601	5353-300534	CAP, MCA 30P
678	C105	5354-332J1HM	CAP, MYL 3300P	600	C602	5353-300534	CAP, MCA 30P
673	C106	5354-333J1HM	CAP, MYL .033μ	596	C603	5345-476B0951	CAP, MINI ELE 47μ/10V
673	C107	5354-333J1HM	CAP, MYL .033μ	601	C604	5354-104593	CAP, MYL .01μ
674	C108	5354-103J1HM	CAP, MYL .01μ	601	C606	5354-104593	CAP, MYL .01μ
662	C109	5345-476D0962	CAP, MINI ELE 47μ/25V	601	C608	5354-104593	CAP, MYL .01μ
662	C110	5345-476D0962	CAP, MINI ELE 47μ/25V	597	C610	5345-477C0962	CAP, MINI ELE 470μ/16V
662	C111	5345-476D0962	CAP, MINI ELE 47μ/25V	597	C611	5345-477C0962	CAP, MINI ELE 470μ/16V
666	C112	5345-474F0962	CAP, MINI ELE 47μ/50V	597	C612	5345-477C0962	CAP, MINI ELE 470μ/16V
664	C113	5345-226D0962	CAP, MINI ELE 22μ/25V	598	C613	5345-477C0962	CAP, MINI ELE 470μ/16V
671	C114	5354-823593	CAP, MYL .082μ	598	C614	5345-227C0962	CAP, MINI ELE 220μ/16V
680	C115	5359-S010J681	CAP, PPP 680P	598	C615	5345-227C0962	CAP, MINI ELE 220μ/16V
669	C116	5354-274593	CAP, MYL .27μ	599	C617	5353-030534	CAP, MCA 3P
667	C117	5342-105F0951	CAP, ELE BP 1μ/50V	599	C618	5353-030504	CAP, MCA 3P
670	C118	5354-104593	CAP, MYL .1μ	599	C619	5353-030504	CAP, MCA 3P
675	C119	5354-472J1HM	CAP, MYL 4700P	602	C620	5353-030504	CAP, MCA 3P
686	C121	5354-183J1HM	CAP, MYL .018μ	602	C621	5354-104593	CAP, MYL .1μ
668	C122	5354-184593	CAP, MYL .18μ	602	C622	5354-104593	CAP, MYL .1μ
677	C123	5354-123J1HM	CAP, MYL .012μ	602	C623	5354-104593	CAP, MYL .1μ
683	C124	5359-S010J391	CAP, PPP 390P	602	C624	5354-104593	CAP, MYL .1μ
665	C125	5345-476D0962	CAP, MINI ELE 47μ/25V	896	C801	5345-476C0962	CAP, MINI ELE 47μ/16V
666	C126	5345-474F0962	CAP, MINI ELE .47μ/50V	898	C803	5353-560534	CAP, MCA 56P
672	C127	5354-563593	CAP, MYL .056μ	895	C804	5345-336C0962	CAP, MINI ELE 33μ/16V
662	C128	5345-476D0962	CAP, MINI ELE 47μ/25V	897	C806	5354-104593	CAP, MYL .1μ
662	C129	5345-476D0962	CAP, MINI ELE 47μ/25V	899	C807	5353-470534	CAP, MCA 47P
670	C130	5354-104593	CAP, MYL .1μ	818	C910	5345-226D0962	CAP, MINI ELE 22μ/25V
670	C131	5354-104593	CAP, MYL .1μ				
670	C132	5354-104593	CAP, MYL .1μ				
660	C133	5345-477C0962	CAP, MINI ELE 470μ/16V				
660	C134	5345-477C0962	CAP, MINI ELE 470μ/16V				
682	C141	5354-102J1HM	CAP, MYL 1000P				
628	C201	5354-222J1HM	CAP, MYL 2200P				
626	C202	5354-223J1HM	CAP, MYL .022μ				
627	C203	5350-S010J471	CAP, PPP 470P				
625	C204	5354-154593	CAP, MYL .15μ				
624	C206	5345-476B0951	CAP, MINI ELE 47μ/10V				
681	C209	5359-S010J471	CAP, PPP 470P				
681	C210	5359-S010J471	CAP, PPP 470P				
670	C211	5354-104593	CAP, MYL .1μ				
685	C212	5361-220JCH	CAP, CER 22P				
670	C213	5354-104593	CAP, MYL .1μ				
661	C214	5345-107D0962	CAP, MINI ELE 100μ/25V				

RESISTORS

520	R3	5134-222J25P	RES, CBN 1/4P 2.2K
520	R4	5134-222J25P	RES, CBN 1/4P 2.2K
518	R5	5134-471J25P	RES, CBN 1/4P 470
518	R6	5134-471J25P	RES, CBN 1/4P 470
517	R7	5134-101J25P	RES, CBN 1/4P 100
517	R8	5134-101J25P	RES, CBN 1/4P 100
516	R9	5134-4R7J25P	RES, CBN 1/4P 4.7
516	R10	5134-4R7J25P	RES, CBN 1/4P 4.7
521	R12	5232-101J16P	RES, CBN 1/6P 100
519	R13	5134-102J25P	RES, CBN 1/4P 1K
519	R14	5134-102J25P	RES, CBN 1/4P 1K
518	R15	5134-471J25P	RES, CBN 1/4P 470
518	R16	5134-471J25P	RES, CBN 1/4P 470
521	R18	5232-101J16P	RES, CBN 1/6P 100
515	R19	5134-1R5J25P	RES, CBN 1/4P 1.5
515	R20	5134-1R5J25P	RES, CBN 1/4P 1.5
788	R24	5232-223J16P	RES, CBN 1/6P 22K
790	R52	5232-224J16P	RES, CBN 1/6P 220K

Ser. No.	Ref. No.	Part No.	Description	Ser. No.	Ref. No.	Part No.	Description
788	R53	5232-223J16P	RES, CBN 1/6P 22K	714	R215	5232-104J16P	RES, CBN 1/6P 100K
787	R54	5232-103J16P	RES, CBN 1/6P 10K	714	R216	5232-104J16P	RES, CBN 1/6P 100K
784	R55	5232-101J16P	RES, CBN 1/6P 100	714	R217	5232-104J16P	RES, CBN 1/6P 100K
794	R59	5232-224J16P	RES, CBN 1/6P 220K	697	R218	5232-100J16P	RES, CBN 1/6P 10
793	R60	5232-104J16P	RES, CBN 1/6P 100K	638	R219	5134-102J25P	RES, CBN 1/4P 1K
792	R61	5232-103J16P	RES, CBN 1/6P 10K	717	IR220	5102-4R75116	RES, FUSE 4.7
791	R65	5232-392J16P	RES, CBN 1/6P 3.9K	717	IR221	5102-4R75116	RES, FUSE 4.7
785	R66	5232-221J16P	RES, CBN 1/6P 220	630	R222	5134-100J25P	RES, CBN 1/4P 10
690	R101	5134-220J25P	RES, CBN 1/4P 22	716	R223	5232-275J16P	RES, CBN 1/6P 2.7M
693	R102	5134-222J25P	RES, CBN 1/4P 2.2K	632	R224	5134-222J25P	RES, CBN 1/4P 2.2K
707	R103	5232-163J16P	RES, CBN 1/6P 16K	632	R225	5134-222J25P	RES, CBN 1/4P 2.2K
704	R104	5232-822J16P	RES, CBN 1/6P 8.2K	632	R226	5134-222J25P	RES, CBN 1/4P 2.2K
695	R105	5134-223J25P	RES, CBN 1/4P 22K	635	R227	5232-222J16P	RES, CBN 1/6P 2.2K
692	R106	5134-102J25P	RES, CBN 1/4P 1K	635	R228	5232-222J16P	RES, CBN 1/6P 2.2K
691	R107	5134-910J25P	RES, CBN 1/4P 91	635	R229	5232-222J16P	RES, CBN 1/6P 2.2K
708	R108	5232-183J16P	RES, CBN 1/6P 18K	705	R251	5232-103J16P	RES, CBN 1/6P 10K
708	R109	5232-183J16P	RES, CBN 1/6P 18K	705	R252	5232-103J16P	RES, CBN 1/6P 10K
692	R110	5134-102J25P	RES, CBN 1/4P 1K	705	R253	5232-103J16P	RES, CBN 1/6P 10K
705	R111	5232-103J16P	RES, CBN 1/6P 10K	705	R254	5232-103J16P	RES, CBN 1/6P 10K
714	R112	5232-104J16P	RES, CBN 1/6P 100K	705	R255	5232-103J16P	RES, CBN 1/6P 10K
694	R113	5134-103J25P	RES, CBN 1/4P 10K	631	R257	5134-102J25P	RES, CBN 1/4P 1K
695	R114	5134-223J25P	RES, CBN 1/4P 22K	582	R301	5134-512J25P	RES, CBN 1/4P 5.1K
713	R115	5232-683J16P	RES, CBN 1/6P 68K	582	R302	5134-512J25P	RES, CBN 1/4P 5.1K
706	R116	5232-153J16P	RES, CBN 1/6P 15K	582	R303	5134-512J25P	RES, CBN 1/4P 5.1K
703	R117	5232-682J16P	RES, CBN 1/6P 6.8K	582	R304	5134-512J25P	RES, CBN 1/4P 5.1K
698	R118	5232-221J16P	RES, CBN 1/6P 220	583	R305	5134-562J25P	RES, CBN 1/4P 5.6K
712	R119	5232-473J16P	RES, CBN 1/6P 47K	583	R306	5134-562J25P	RES, CBN 1/4P 5.6K
694	R120	5134-103J25P	RES, CBN 1/4P 10K	583	R307	5134-562J25P	RES, CBN 1/4P 5.6K
705	R121	5232-103J16P	RES, CBN 1/6P 10K	583	R308	5134-562J25P	RES, CBN 1/4P 5.6K
710	R122	5232-273J16P	RES, CBN 1/6P 27K	579	R309	5134-102J25P	RES, CBN 1/4P 1K
705	R124	5232-103J16P	RES, CBN 1/6P 10K	579	R310	5134-102J25P	RES, CBN 1/4P 1K
714	R126	5232-104J16P	RES, CBN 1/6P 100K	579	R311	5134-102J25P	RES, CBN 1/4P 1K
714	R127	5232-104J16P	RES, CBN 1/6P 100K	579	R312	5134-102J25P	RES, CBN 1/4P 1K
705	R128	5232-103J16P	RES, CBN 1/6P 10K	579	R313	5134-102J25P	RES, CBN 1/4P 1K
705	R129	5232-103J16P	RES, CBN 1/6P 10K	579	R314	5134-102J25P	RES, CBN 1/4P 1K
721	R130	5232-224J16P	RES, CBN 1/6P 220K	579	R315	5134-102J25P	RES, CBN 1/4P 1K
714	R131	5232-104J16P	RES, CBN 1/6P 100K	579	R316	5134-102J25P	RES, CBN 1/4P 1K
702	R132	5232-562J16P	RES, CBN 1/6P 5.6K	573	R317	5134-390J25P	RES, CBN 1/4P 39
699	R133	5232-102J16P	RES, CBN 1/6P 1K	573	R318	5134-390J25P	RES, CBN 1/4P 39
700	R134	5134-563J25P	RES, CBN 1/4P 56K	573	R319	5134-390J25P	RES, CBN 1/4P 39
706	R135	5232-153J16P	RES, CBN 1/6P 15K	573	R320	5134-390J25P	RES, CBN 1/4P 39
706	R136	5232-153J16P	RES, CBN 1/6P 15K	575	R321	5134-101J25P	RES, CBN 1/4P 100
711	R137	6232-393J16P	RES, CBN 1/6P 39K	575	R322	5134-101J25P	RES, CBN 1/4P 100
709	R138	5232-223J16P	RES, CBN 1/6P 22K	575	R323	5134-101J25P	RES, CBN 1/4P 100
701	R139	5232-332J16P	RES, CBN 1/6P 3.3K	575	R324	5134-101J25P	RES, CBN 1/4P 100
710	R140	5232-273J16P	RES, CBN 1/6P 27K	575	R325	5134-101J25P	RES, CBN 1/4P 100
697	R141	5232-100J16P	RES, CBN 1/6P 10	575	R326	5134-101J25P	RES, CBN 1/4P 100
697	R142	5232-100J16P	RES, CBN 1/6P 10	575	R327	5134-101J25P	RES, CBN 1/4P 100
697	R143	5232-100J16P	RES, CBN 1/6P 10	575	R328	5134-101J25P	RES, CBN 1/4P 100
705	R145	5232-103J16P	RES, CBN 1/6P 10K	577	R329	5134-221J25P	RES, CBN 1/4P 220
689	R150	5134-4R7J25P	RES, CBN 1/4P 4.7	577	R330	5134-221J25P	RES, CBN 1/4P 220
689	R151	5134-4R7J25P	RES, CBN 1/4P 4.7	575	R331	5134-101J25P	RES, CBN 1/4P 100
696	R152	5232-4R7J16P	RES, CBN 1/6P 4.7	575	R332	5134-101J25P	RES, CBN 1/4P 100
689	R153	5134-4R7J25P	RES, CBN 1/4P 4.7	578	R333	5134-471J25P	RES, CBN 1/4P 470
720	IR154	5102-4R75116	RES, FUSE 4.7	578	R334	5134-471J25P	RES, CBN 1/4P 470
720	IR155	5102-4R75116	RES, FUSE 4.7	575	R335	5134-101J25P	RES, CBN 1/4P 100
718	R156	5232-105J16P	RES, CBN 1/6P 1M	575	R336	5134-101J25P	RES, CBN 1/4P 100
636	R201	5232-333J16P	RES, CBN 1/6P 33K	572	R337	5134-100J25P	RES, CBN 1/4P 10
635	R202	5232-222J16P	RES, CBN 1/6P 2.2K	572	R338	5134-100J25P	RES, CBN 1/4P 10
634	R203	5134-104J25P	RES, CBN 1/4P 100K	572	R339	5134-100J25P	RES, CBN 1/4P 10
633	R204	5134-103J25P	RES, CBN 1/4P 10K	572	R340	5134-100J25P	RES, CBN 1/4P 10
637	R205	5232-104J16P	RES, CBN 1/6P 100K	580	R341	5134-222J25P	RES, CBN 1/4P 2.2K
695	R207	5134-223J25P	RES, CBN 1/4P 22K	580	R342	5134-222J25P	RES, CBN 1/4P 2.2K
714	R209	5232-104J16P	RES, CBN 1/6P 100K	575	R343	5134-101J25P	RES, CBN 1/4P 100
714	R210	5232-104J16P	RES, CBN 1/6P 100K	575	R344	5134-101J25P	RES, CBN 1/4P 100
715	R211	5232-334J16P	RES, CBN 1/6P 330K	578	R345	5134-471J25P	RES, CBN 1/4P 470
715	R212	5232-334J16P	RES, CBN 1/6P 330K	578	R346	5134-471J25P	RES, CBN 1/4P 470
697	R213	5232-100J16P	RES, CBN 1/6P 10	575	R347	5134-101J25P	RES, CBN 1/4P 100
714	R214	5232-104J16P	RES, CBN 1/6P 100K	575	R348	5134-101J25P	RES, CBN 1/4P 100

Ser. No.	Ref. No.	Part No.	Description	Ser. No.	Ref. No.	Part No.	Description
580	R349	5134-222J25P	RES, CBN 1/4P 2.2K	605	R625	5134-221J25P	RES, CBN 1/4P 220
580	R350	5134-222J25P	RES, CBN 1/4P 2.2K	604	R626	5134-100J25P	RES, CBN 1/4P 10
576	R351	5134-101J25P	RES, CBN 1/4P 100	604	R627	5134-100J25P	RES, CBN 1/4P 10
576	R352	5134-101J25P	RES, CBN 1/4P 100	613	R631	5134-331J25P	RES, CBN 1/4P 330
578	R353	5134-471J25P	RES, CBN 1/4P 470	613	R632	5134-331J25P	RES, CBN 1/4P 330
578	R354	5134-471J25P	RES, CBN 1/4P 470	615	R633	5232-331J16P	RES, CBN 1/6P 330
576	R355	5134-101J25P	RES, CBN 1/4P 100	613	R634	5134-331J25P	RES, CBN 1/4P 330
576	R356	5134-101J25P	RES, CBN 1/4P 100	607	R635	5232-221J16P	RES, CBN 1/6P 220
572	R357	5134-100J25P	RES, CBN 1/4P 10	612	R636	5134-221J25P	RES, CBN 1/4P 220
572	R358	5134-100J25P	RES, CBN 1/4P 10	607	R637	5232-221J16P	RES, CBN 1/6P 220
572	R359	5134-100J25P	RES, CBN 1/4P 10	607	R638	5232-221J16P	RES, CBN 1/6P 220
572	R360	5134-100J25P	RES, CBN 1/4P 10	611	R639	5232-101J16P	RES, CBN 1/6P 100
576	R361	5134-101J25P	RES, CBN 1/4P 100	611	R640	5232-101J16P	RES, CBN 1/6P 100
576	R362	5134-101J25P	RES, CBN 1/4P 100	607	R641	5232-221J16P	RES, CBN 1/6P 220
574	R363	5134-470J25P	RES, CBN 1/4P 47	607	R642	5232-221J16P	RES, CBN 1/6P 220
574	R364	5134-470J25P	RES, CBN 1/4P 47	607	R643	5232-221J16P	RES, CBN 1/6P 220
577	R365	5134-221J25P	RES, CBN 1/4P 220	904	R801	5232-750J16P	RES, CBN 1/6P 75
577	R366	5134-221J25P	RES, CBN 1/4P 220	900	R805	5134-331J25P	RES, CBN 1/4P 330
574	R367	5134-470J25P	RES, CBN 1/4P 47	901	R807	5134-221J25P	RES, CBN 1/4P 220
574	R368	5134-470J25P	RES, CBN 1/4P 47	903	R809	5232-101J16P	RES, CBN 1/6P 100
786	R369	5134-182J25P	RES, CBN 1/4P 1.8K	902	R810	5134-101J25P	RES, CBN 1/4P 100
786	R370	5134-182J25P	RES, CBN 1/4P 1.8K	822	R910	5232-473J16P	RES, CBN 1/6P 47K
786	R371	5134-182J25P	RES, CBN 1/4P 1.8K	821	R911	5134-470J25P	RES, CBN 1/4P 47
786	R372	5134-182J25P	RES, CBN 1/4P 1.8K	823	R912	5232-271J16P	RES, CBN 1/6P 270
786	R373	5134-182J25P	RES, CBN 1/4P 1.8K	824	R913	5232-392J16P	RES, CBN 1/6P 3.9K
786	R374	5134-182J25P	RES, CBN 1/4P 1.8K				
786	R375	5134-182J25P	RES, CBN 1/4P 1.8K				
786	R376	5134-182J25P	RES, CBN 1/4P 1.8K				
581	R377	5134-392J25P	RES, CBN 1/4P 3.9K	652	IC101	5653-CXA1081S	IC, LINEAR
581	R378	5134-392J25P	RES, CBN 1/4P 3.9K	651	IC102	5654-M61594FP	IC, DIGITAL
582	R379	5134-512J25P	RES, CBN 1/4P 5.1K	653	IC103	5653-LA6520	IC, LINEAR
582	R380	5134-512J25P	RES, CBN 1/4P 5.1K	621	IC201	5654-M65820FP	IC, DIGITAL
572	R381	5134-100J25P	RES, CBN 1/4P 10	654	IC203	5653-LA6515	IC, LINEAR
572	R382	5134-100J25P	RES, CBN 1/4P 10	801	IC501	5653-NJM4565D	IC, LINEAR
582	R383	5134-512J25P	RES, CBN 1/4P 5.1K	591	IC601	5654-SM5840CP	IC, DIGITAL
582	R384	5134-512J25P	RES, CBN 1/4P 5.1K	592	IC602	5654-H74H04P	IC, DIGITAL
584	R393	5134-104J25P	RES, CBN 1/4P 100K	593	IC603	5654-H74H164P	IC, DIGITAL
584	R394	5134-104J25P	RES, CBN 1/4P 100K	593	IC604	5654-H74H164P	IC, DIGITAL
789	R399	5232-154J16P	RES, CBN 1/6P 150K	593	IC605	5654-H74H164P	IC, DIGITAL
806	R501	5134-100J25P	RES, CBN 1/4P 10	593	IC606	5654-H74H164P	IC, DIGITAL
806	R502	5134-100J25P	RES, CBN 1/4P 10	593	IC607	5654-H74H164P	IC, DIGITAL
808	R503	5134-103J25P	RES, CBN 1/4P 10K	593	IC608	5654-H74H164P	IC, DIGITAL
808	R504	5134-103J25P	RES, CBN 1/4P 10K	593	IC609	5654-H74H164P	IC, DIGITAL
807	R505	5134-510J25P	RES, CBN 1/4P 51	594	IC611	5654-PCM61P	IC, DIGITAL
807	R506	5134-510J25P	RES, CBN 1/4P 51	594	IC612	5654-PCM61P	IC, DIGITAL
610	R601	5232-105J16P	RES, CBN 1/6P 1M	594	IC613	5654-PCM61P	IC, DIGITAL
603	R602	5134-3R3J25P	RES, CBN 1/4P 3.3	594	IC614	5654-PCM61P	IC, DIGITAL
603	R603	5134-3R3J25P	RES, CBN 1/4P 3.3	891	IC801	5654-H74H02P	IC, DIGITAL
603	R604	5134-3R3J25P	RES, CBN 1/4P 3.3				
603	R605	5134-3R3J25P	RES, CBN 1/4P 3.3	502	△ Q1	5614-2012	XISTOR, NPN A
609	R606	5232-474J16P	RES, CBN 1/6P 470K	501	△ Q2	5612-1375	XISTOR, PNP A
609	R607	5232-474J16P	RES, CBN 1/6P 470K	504	Q3	5611-1015(GR)	XISTOR, PNP R
606	R608	5134-224J25P	RES, CBN 1/4P 220K	503	Q4	5613-1815(GR)	XISTOR, NPN R
608	R609	5232-224J16P	RES, CBN 1/6P 220K	504	Q5	5611-1015(GR)	XISTOR, PNP R
610	R610	5232-105J16P	RES, CBN 1/6P 1M	503	Q6	5613-1815(GR)	XISTOR, NPN R
610	R611	5232-105J16P	RES, CBN 1/6P 1M	502	△ Q7	5614-2012	XISTOR, NPN A
609	R6112	5232-474J16P	RES, CBN 1/6P 470K	501	△ Q8	5612-1375	XISTOR, PNP A
609	R613	5232-474J16P	RES, CBN 1/6P 470K	504	Q9	5611-1015(GR)	XISTOR, PNP R
616	R614	5232-184J16P	RES, CBN 1/6P 180K	503	Q10	5613-1815(GR)	XISTOR, NPN R
608	R615	5232-184J16P	RES, CBN 1/6P 180K	504	Q11	5611-1015(GR)	XISTOR, PNP R
610	R616	5232-105J16P	RES, CBN 1/6P 1M	503	Q12	5613-1815(GR)	XISTOR, NPN R
610	R617	5232-105J16P	RES, CBN 1/6P 1M	771	Q51	5611-1015(GR)	XISTOR, PNP R
607	618	5232-221J16P	RES, CBN 1/6P 220	771	Q54	5611-1015(GR)	XISTOR, PNP R
607	619	5232-221J16P	RES, CBN 1/6P 220	774	Q55	5613-RN1202	XISTOR, NPN R
607	620	5232-221J16P	RES, CBN 1/6P 220	772	Q56	5613-1815(GR)	XISTOR, NPN R
607	621	5232-221J16P	RES, CBN 1/6P 220	656	Q101	5612-647(C)	XISTOR, PNP A
605	622	5134-221J25P	RES, CBN 1/4P 220	655	Q102	5613-1815(GR)	XISTOR, NPN R
607	R623	5232-221J16P	RES, CBN 1/6P 220	655	Q103	5613-1815(GR)	XISTOR, NPN R
607	R624	5232-221J16P	RES, CBN 1/6P 220	655	Q104	5613-1815(GR)	XISTOR, NPN R
				622	Q201	5613-1815(GR)	XISTOR, NPN R

INTEGRATED CIRCUITS

TRANSISTORS

Ser. No.	Ref. No.	Part No.	Description	Ser. No.	Ref. No.	Part No.	Description
563	Q301	5611-1015L(GR)	XISTOR, PNP R	849	CN113	4443-0501140	CONNECTOR
563	Q302	5611-1015L(GR)	XISTOR, PNP R	848	CN114	4443-0801140	CONNECTOR
561	Q303	5613-1815L(GR)	XISTOR, NPN R	848	CN115	4443-0801140	CONNECTOR
561	Q304	5613-1815L(GR)	XISTOR, NPN R	850	CN117	4443-0401140	CONNECTOR
561	Q305	5613-1815L(GR)	XISTOR, NPN R	856	CN201	4443-05501030	CONNECTOR
561	Q306	5613-1815L(GR)	XISTOR, NPN R	855	CN501	4443-030185	CONNECTOR
563	Q307	5611-1015L(GR)	XISTOR, PNP R	855	CN502	4443-030185	CONNECTOR
563	Q308	5611-1015L(GR)	XISTOR, PNP R	855	CN503	4443-030185	CONNECTOR
561	Q309	5613-1815L(GR)	XISTOR, NPN R	841	△ J301	4489-02601004	4 PIN JACK, FIXED/VARIABLE OUTPUT
561	Q310	5613-1815L(GR)	XISTOR, NPN R				
563	Q311	5611-1015L(GR)	XISTOR, PNP R	844	△ J801	4481-00501	1 PIN JACK, DIGITAL OUTPUT (COAXIAL)
563	Q312	5611-1015L(GR)	XISTOR, PNP R				
562	Q313	5611-950 (Y)	XISTOR, PNP R	846	J910	4451-00184	1 PIN JACK, REMOTE INPUT
562	Q314	5611-950 (Y)	XISTOR, PNP R	846	J911	4451-00184	1 PIN JACK, REMOTE OUTPUT
561	Q315	5613-1815L(GR)	XISTOR, NPN R	870	△ JL101	4242-R0107111	JUMPER LEAD
561	Q316	5613-1815L(GR)	XISTOR, NPN R	816	PH911	5624-ON3131	PHOTO COUPLR
562	Q317	5611-950 (Y)	XISTOR, PNP R	841	RC250	5212-S0305103	R COMPOSITE, 10 K X5
562	Q318	5611-950 (Y)	XISTOR, PNP R	719	TP101	4214-132	TERMINAL
561	Q319	5613-1815L(GR)	XISTOR, NPN R	719	TP102	4214-132	TERMINAL
561	Q320	5613-1815L(GR)	XISTOR, NPN R	719	TP103	4214-132	TERMINAL
562	Q321	5611-950 (Y)	XISTOR, PNP R	719	TP104	4214-132	TERMINAL
562	Q322	5611-950 (Y)	XISTOR, PNP R	639	TP201	4214-132	TERMINAL
561	Q323	5613-1815L(GR)	XISTOR, NPN R	639	TP202	4214-132	TERMINAL
561	Q324	5613-1815L(GR)	XISTOR, NPN R	639	TP203	4214-132	TERMINAL
564	Q325	5618-SK246GR2	FET, N-CH	639	TP204	4214-132	TERMINAL
564	Q326	5618-SK246GR2	FET, N-CH	639	TP205	4214-132	TERMINAL
564	Q327	5618-SK246GR2	FET, N-CH	586	TP301	4214-132	TERMINAL
564	Q328	5618-SK246GR2	FET, N-CH	876	TP302	4214-132	TERMINAL
565	Q329	5616-2SK246BL	FET, N-CH	906	TP801	4214-132	TERMINAL
565	Q330	5616-2SK246BL	FET, N-CH	595	X601	5691-S1701173	XTAL, OSC, 16.9344 MHz
773	Q331	5613-2878 (B)	XISTOR, NPN R				
773	Q332	5613-2878 (B)	XISTOR, NPN R				
773	Q333	5613-2878 (B)	XISTOR, NPN R				
773	Q334	5613-2878 (B)	XISTOR, NPN R				
773	Q335	5613-2878 (B)	XISTOR, NPN R				
773	Q336	5613-2878 (B)	XISTOR, NPN R	727	C401	5345-476B0951	CAP, MINI ELE 47μ10V
773	Q337	5613-2878 (B)	XISTOR, NPN R	728	C402	5354-104593	CAP, MYL .1μ
773	Q338	5613-2878 (B)	XISTOR, NPN R	728	C402	5354-104593	CAP, MYL .1μ
815	Q910	5611-RN2201	XISTOR, PNP R	750	C404	5345-476B0951	CAP, MINI ELE 47μ10V

PCB-2 FRONT P.C. BOARD

CAPACITORS

727	C401	5345-476B0951	CAP, MINI ELE 47μ10V
728	C402	5354-104593	CAP, MYL .1μ
728	C402	5354-104593	CAP, MYL .1μ
750	C404	5345-476B0951	CAP, MINI ELE 47μ10V

RESISTORS

730	R401	5134-4R7J25P	RES, CBN 1/4P 4.7
753	R402	5134-102J25P	RES, CBN 1/4P 1K
751	R403	5134-100J25P	RES, CBN 1/4P 10
754	R404	5134-103J25P	RES, CBN 1/4P 10K
754	R405	5134-103J25P	RES, CBN 1/4P 10K
754	R406	5134-103J25P	RES, CBN 1/4P 10K
754	R407	5134-103J25P	RES, CBN 1/4P 10K
752	R408	5134-101J25P	RES, CBN 1/4P 100
755	R409	5134-221J25P	RES, CBN 1/4P 220

INTEGRATED CIRCUIT

725	IC401	5654-M957-243	IC, DIGITAL
-----	-------	---------------	-------------

DIODES

747	D401	5631-1S2473	DIODE, DET
747	D402	5631-1S2473	DIODE, DET
747	D403	5631-1S2473	DIODE, DET
747	D404	5631-1S2473	DIODE, DET
747	D405	5631-1S2473	DIODE, DET
747	D406	5631-1S2473	DIODE, DET
747	D407	5631-1S2473	DIODE, DET
747	D408	5631-1S2473	DIODE, DET
747	D409	5631-1S2473	DIODE, DET
747	D410	5631-1S2473	DIODE, DET
747	D411	5631-1S2473	DIODE, DET
747	D412	5631-1S2473	DIODE, DET
748	D413	5631-1SS133	DIODE, DET
748	D414	5631-1SS133	DIODE, DET

DIODES

507	D13	5635-HZ12B2L	DIODE, ZENER
507	D14	5635-HZ12B2L	DIODE, ZENER
506	D15	5635-HZ6B2L	DIODE, ZENER
506	D16	5635-HZ6B2L	DIODE, ZENER
775	D17	5631-1S2473	DIODE, DET
776	D53	5631-1SS133	DIODE, DET
777	D54	5635-HZ6A2L	DIODE, ZENER
776	D55	5631-1SS133	DIODE, DET
657	D103	5631-1SS133	DIODE, DET
658	D106	5631-1SS133	DIODE, DET

CONTROLS

688	VR101	5101-22301934	RES, SEMI FIX 22K, EF BALANCE
687	VR102	5101-50201934	RES, SEMI FIX 5K, FOCUS OFFSET
614	VR601	5101-10401934	RES, SEMI FIX 100K, LOW LEVEL LINEARITY
614	VR602	5101-10401934	RES, SEMI FIX 100K, LOW LEVEL LINEARITY
614	VR603	5101-10401934	RES, SEMI FIX 100K, LOW LEVEL LINEARITY
614	VR604	5101-10401934	RES, SEMI FIX 100K, LOW LEVEL LINEARITY

COILS

642	L201	5995-1R5J107	COIL W/CORE
893	T801	5933-S0801	COIL CASE, 10

MISCELLANEOUS

854	CN1	4443-050185	CONNECTOR
853	CN2	4443-070185	CONNECTOR

Ser. No.	Ref. No.	Part No.	Description
MISCELLANEOUS			
857	CN410	4443-05401030	CONNECTOR
741	FL401	5722-046	TUBE DISPLAY
745	SW401	4437-01202	SWITCH, PU-TC, 8
745	SW402	4437-01202	SWITCH, PU-TC, 9
745	SW403	4437-01202	SWITCH, PU-TC, 10
743	SW406	4437-01201	SWITCH, PU-TC, DISPLAY
745	SW409	4437-01202	SWITCH, PU-TC, +10
745	SW410	4437-01202	SWITCH, PU-TC, 1
745	SW411	4437-01202	SWITCH, PU-TC, 2
745	SW412	4437-01202	SWITCH, PU-TC, 3
745	SW413	4437-01202	SWITCH, PU-TC, 4
745	SW414	4437-01202	SWITCH, PU-TC, 5
745	SW415	4437-01202	SWITCH, PU-TC, 6
745	SW416	4437-01202	SWITCH, PU-TC, 7
743	SW418	4437-01201	SWITCH, PU-TC, TIME
743	SW419	4437-01201	SWITCH, PU-TC, REPEAT
743	SW422	4437-01201	SWITCH, PU-TC, CLEAR
743	SW423	4437-01201	SWITCH, PU-TC, PROGRAM
743	SW424	4437-01201	SWITCH, PU-TC, CHECK
743	SW425	4437-01201	SWITCH, PU-TC, OPEN/CLOSE
745	SW426	4437-01202	SWITCH, PU-TC, STOP
745	SW427	4437-01202	SWITCH, PU-TC, PLAY
745	SW428	4437-01202	SWITCH, PU-TC, PAUSE
745	SW429	4437-01202	SWITCH, PU-TC, SKIP FORWARD
745	SW430	4437-01202	SWITCH, PU-TC, SKIP REVERSE
745	SW431	4437-01202	SWITCH, PU-TC, FORWARD SEARCH
745	SW432	4437-01202	SWITCH, PU-TC, REVERSE SEARCH
742	RC401	6143-00802	RECEIV BLOCK, REMOTE SENSOR
865	W-401	4163-0120020	CONNECTOR W/W

PCB-3 VOLUME P.C. BOARD

Ser. No.	Ref. No.	Part No.	Description
CAPACITOR			
804	C505	5354-104593	CAP, MYL .1μ
CONTROLS			
838	VR301/302	5113-S0202502	RES, V CBN 16 5K, OUTPUT LEVEL
COIL			
810	L501	5995-1R0J107	COIL W/CORE
MISCELLANEOUS			
845	J501	4451-51501	1 PIN JACK, HEADPHONES
878	LUG1	4162-00601500	LUG W/WIRE, W-511
866	W-510	4163-0108020	CONNECTOR W/W
873		2240-Z031	HOLDER (X3)

PCB-4 POWER SUPPLY P. C. BOARD

Ser. No.	Ref. No.	Part No.	Description
CAPACITORS			
836B	△ C1	5352-1030958	CAP, MTL .01μ
537	C2	5354-104593	CAP, MYL .1μ
537	C3	5354-104593	CAP, MYL .1μ
537	C4	5354-104593	CAP, MYL .1μ
537	C5	5354-104593	CAP, MYL .1μ
537	C6	5354-104593	CAP, MYL .1μ
535	C7	5345-226F0962	CAP, MINI ELE 22μ/50V
534	C9	5345-477E0962	CAP, MINI ELE 470μ/35V
531	C10	5345-228D0962	CAP, MINI ELE 2200μ/25V
531	C11	5345-228D0962	CAP, MINI ELE 2200μ/25V
532	C16	5345-478C0962	CAP, MINI ELE 4700μ/16V
532	C17	5345-478C0962	CAP, MINI ELE 4700μ/16V
539	C30	5359-S010J471	CAP, PPP 470P
544	C32	5345-107B0962	CAP, MINI ELE 100μ/10V
546	C33	5359-S010J101	CAP, PPP 100P
536	C51	5345-226D0962	CAP, MINI ELE 22μ/25V
533	C57	5345-108D0962	CAP, MINI ELE 1000μ/25V

Ser. No.	Ref. No.	Part No.	Description
RESISTORS			
022B	△ R1	5135-335J50P	RES, CBN 1/2P 3.3M
542	R29	5134-223J25P	RES, CBN 1/4P 22K
541	R51	5134-182J25P	RES, CBN 1/4P 1.8K
540	R56	5135-471J50P	RES, CBN 1/2P 470

Ser. No.	Ref. No.	Part No.	Description
DIODES			
525	△ D1	5632-S5566B	DIODE, RECT
525	△ D2	5632-S5566B	DIODE, RECT
525	△ D3	5632-S5566B	DIODE, RECT
525	△ D4	5632-S5566B	DIODE, RECT
526	△ D5	5632-S5566B	DIODE, RECT
526	△ D6	5632-S5566B	DIODE, RECT
526	△ D7	5632-S5566B	DIODE, RECT
526	△ D8	5632-S5566B	DIODE, RECT
525	△ D9	5632-S5566B	DIODE, RECT
525	△ D10	5632-S5566B	DIODE, RECT
522	D11	5635-HZ5B2	DIODE, ZENER
523	D12	5635-HZ27-2	DIODE, ZENER
526	△ D19	5632-S5566B	DIODE, RECT
526	△ D20	5632-S5566B	DIODE, RECT
525	△ D51	5632-S5566B	DIODE, RECT
525	△ D52	5632-S5566B	DIODE, RECT
525	△ D56	5632-S5566B	DIODE, RECT
524	D57	5635-HZ9B2L	DIODE, ZENER

Ser. No.	Ref. No.	Part No.	Description
TRANSFORMER			
831B	△ T1	5584-T1502	XFORMER, POWER

Ser. No.	Ref. No.	Part No.	Description
MISCELLANEOUS			
868	JL1	4242-R0505181	JUMPER LEAD
869	JL2	4242-R0507181	JUMPER LEAD
840	△ SW1	4433-01301	PUSH SWITCH, POWER
877	△ TM1	4214-122	TERMINAL
877	△ TM2	4214-122	TERMINAL
874		2240-Z072	HOLDER, JL2
875		2240-Z052	HOLDER, JL1

Ser. No.	Ref. No.	Part No.	Description
CHASSIS MISCELLANEOUS			
871	JL401	4242-S0330181	JUMPER LEAD
863	LCN113	4163-03212005	CONNECTOR W/W
861	LCN114	4163-03211008	CONNECTOR W/W
862	LCN115	4163-03210008	CONNECTOR W/W
864	LCN117	4163-03207004	CONNECTOR W/W
879	LUG2	4211-4	LUG
833	△ P1	4161-03701220	AC CORD W/PLUG

Ser. No.	Ref. No.	Part No.	Description
PACKAGE PARTS LIST			
023		1756-03108	LABEL, (I) LABEL (X2)
026		1111-M30253	OWNER GUIDE, SAFETY GUIDE
105		1111-0640M152	OWNER GUIDE, IB
114		1221-28130	CARTON BOX G
114		1221-28131	CARTON BOX CB
115		1222-7366	CUSHION, R
116		1222-7367	CUSHION, L
117		1223-R0420055	SOFT SHEET, FRONT PANEL
118		1223-00207018	SOFT SHEET, LID
119		1241-R0160601	POLYETHY BAG, SET
120		1241-R0123351	POLYETHY BAG, IB
834		4161-04601102	CORD W/PLUG (RCA TYPE)
880		4191-0355	BATTERY, DRY
881		6142-07404	CONT BLOCK

IC101 : CXA1081S
RF Amp.

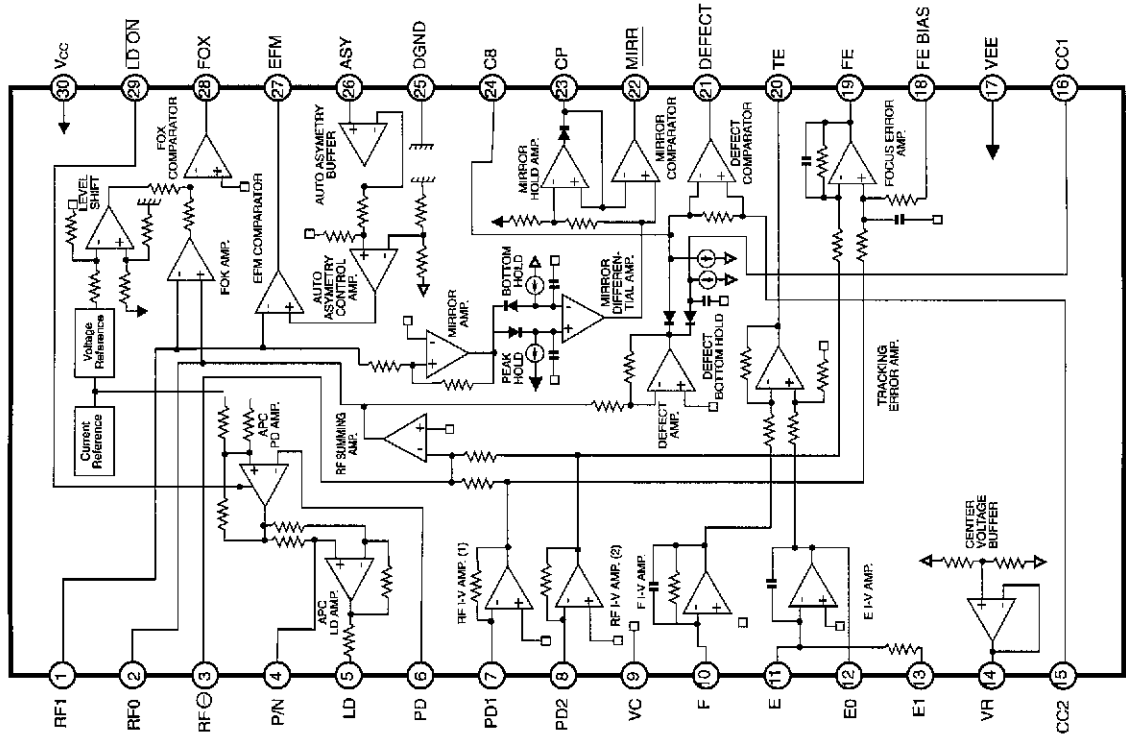

IC102 : M51594FP
Optical Pick-up Servo Control

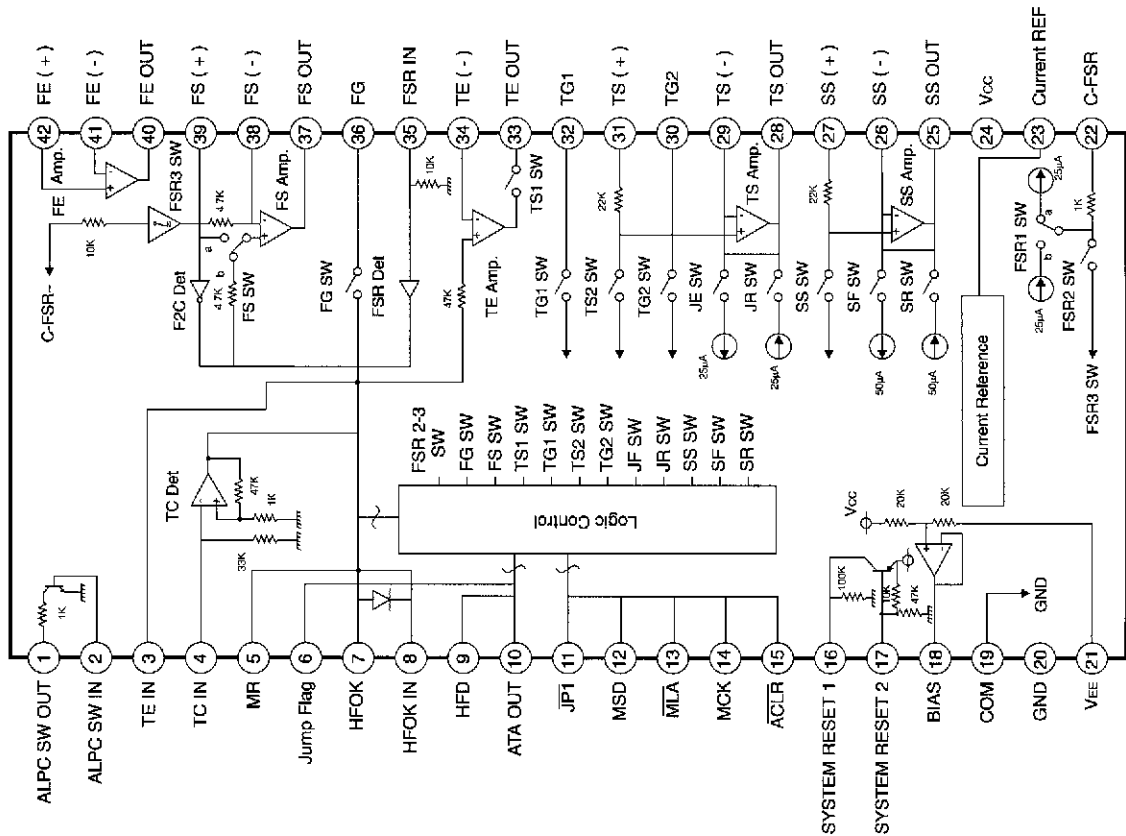

IC201 : M65820FP
Digital Signal Processor

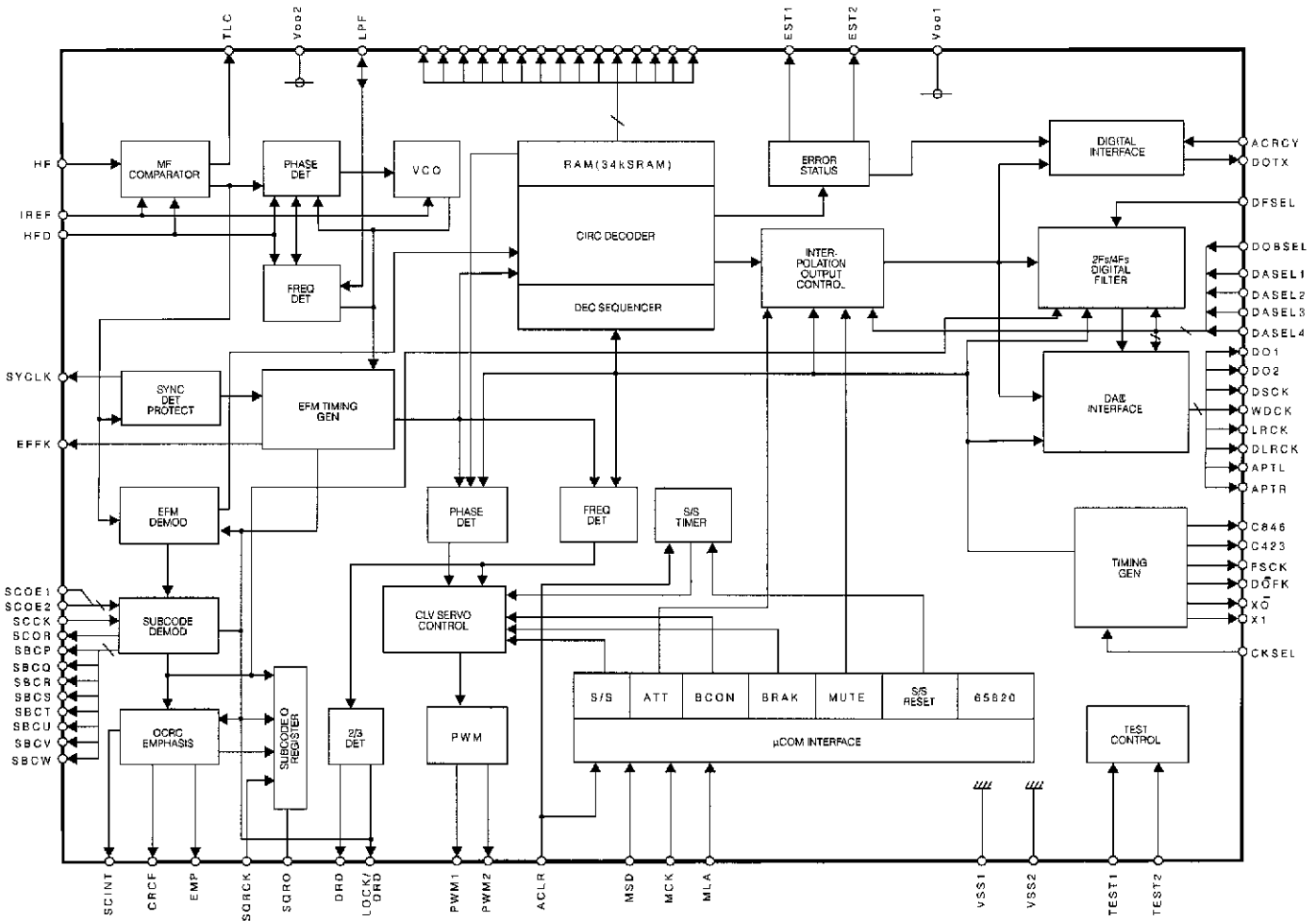

IC201

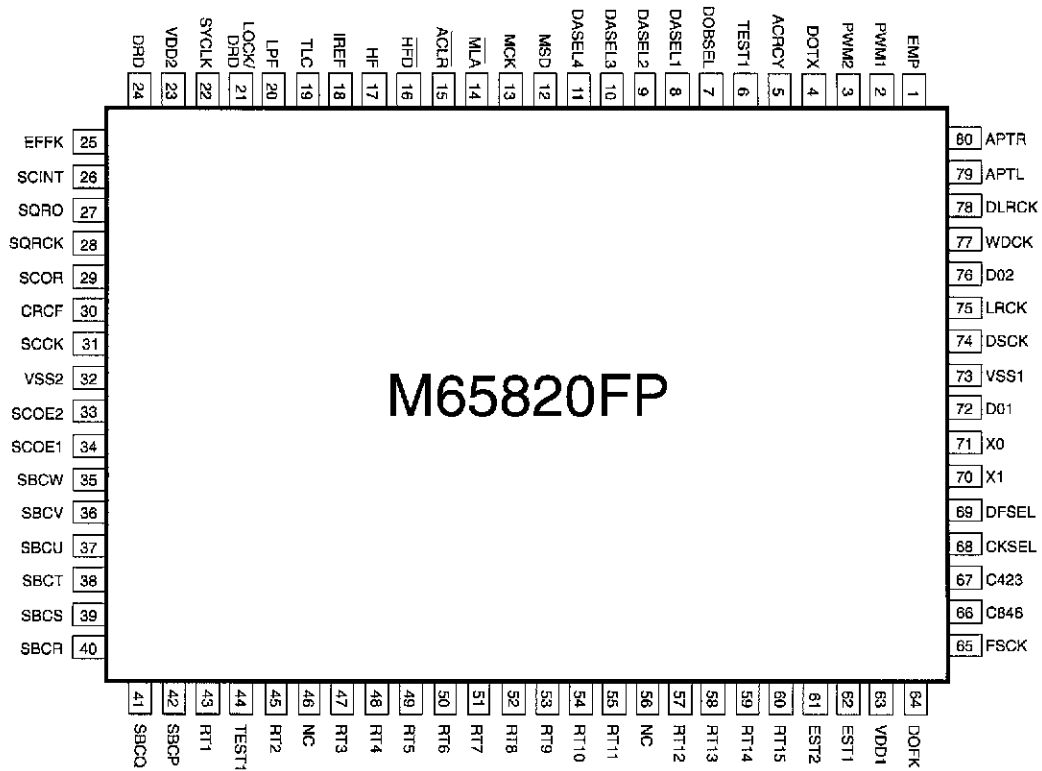

IC401 : M957-243
Microcomputer

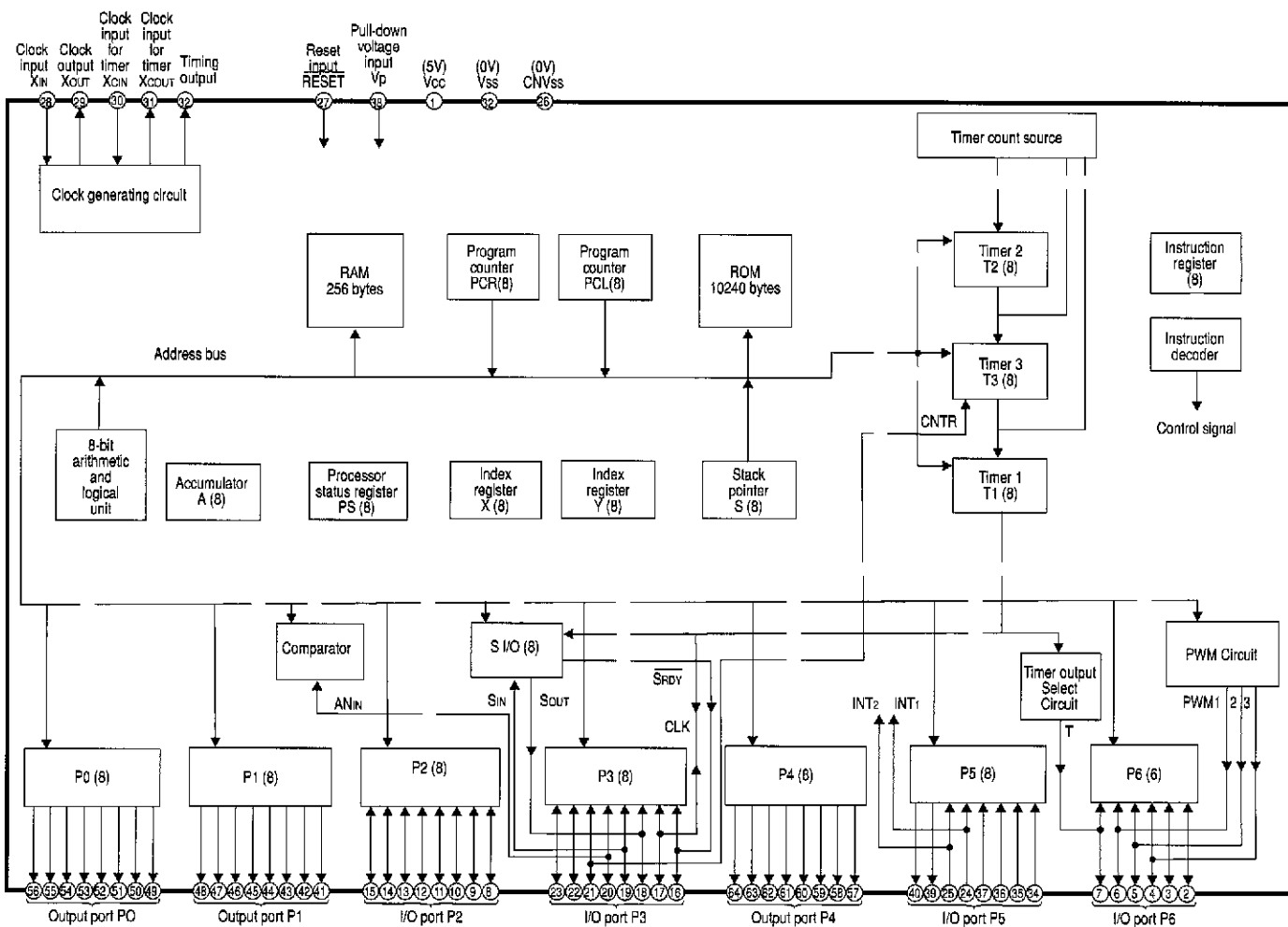

IC501 : NJM4565D
Headphone Amp.

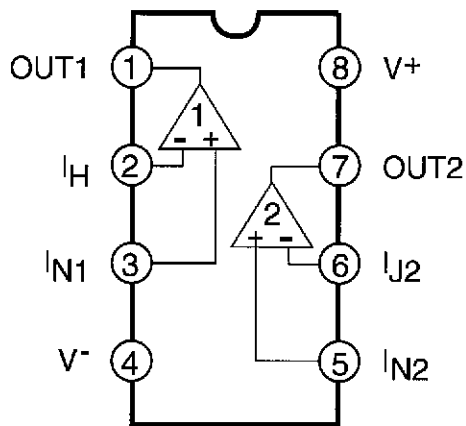

IC601 : SM5840CP
8 fs Digital Filter

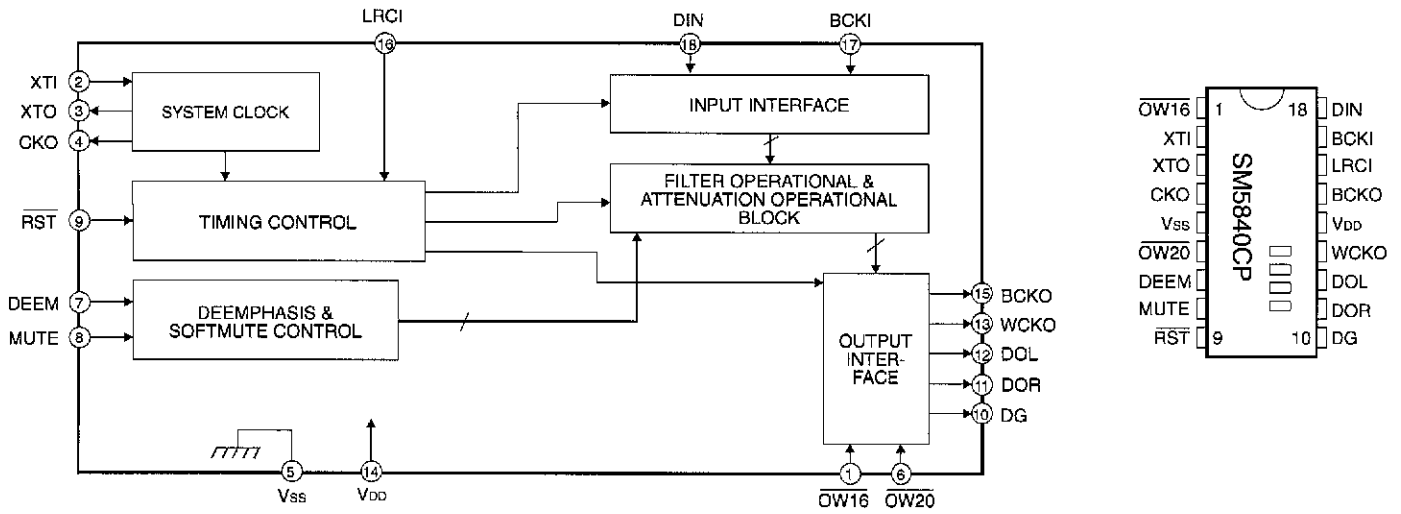

IC602 : H74H04P
Hex Inverter

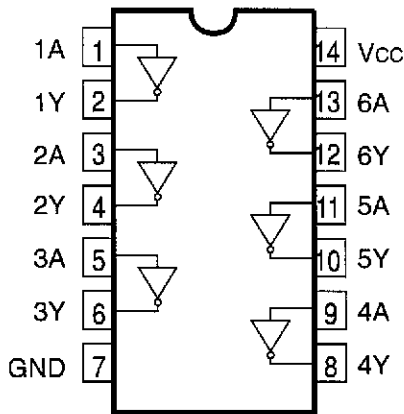

IC603 : H74H164P
8-bit Shift Register

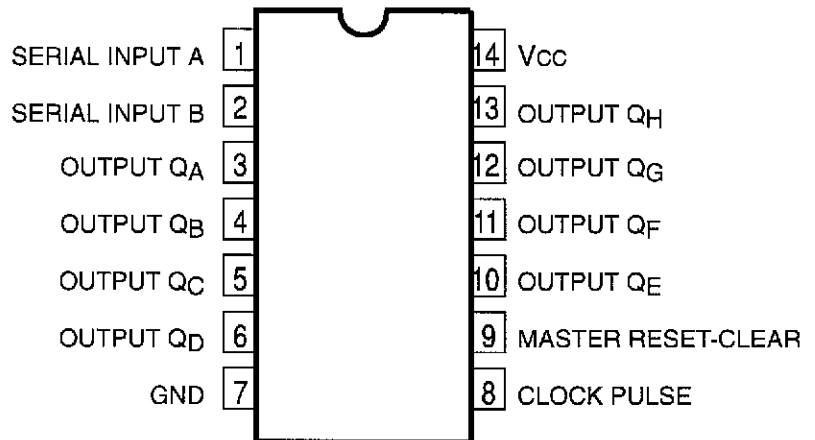

IC603

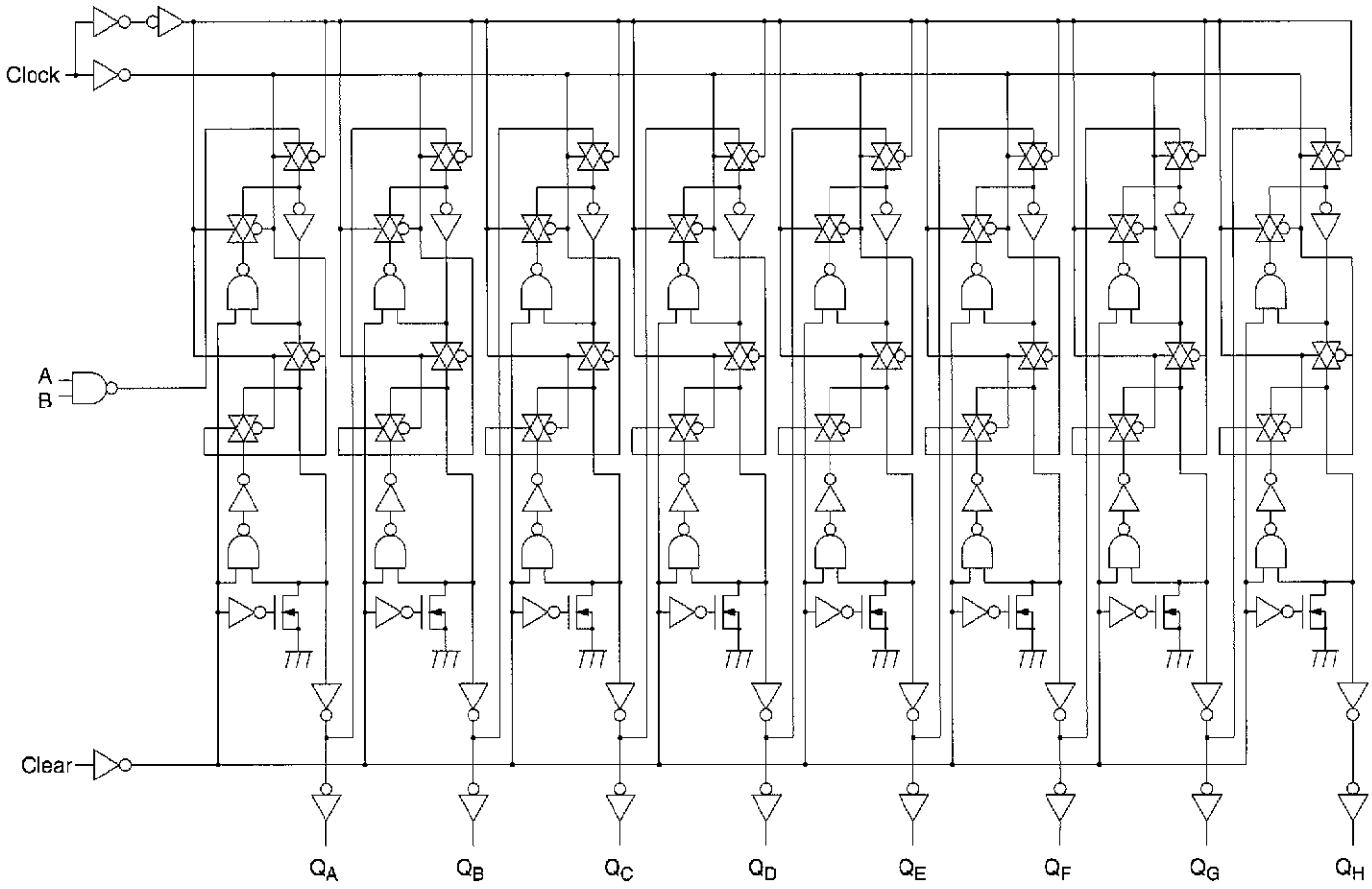

**IC611 - 614 : PCM61P
D/A Converter**

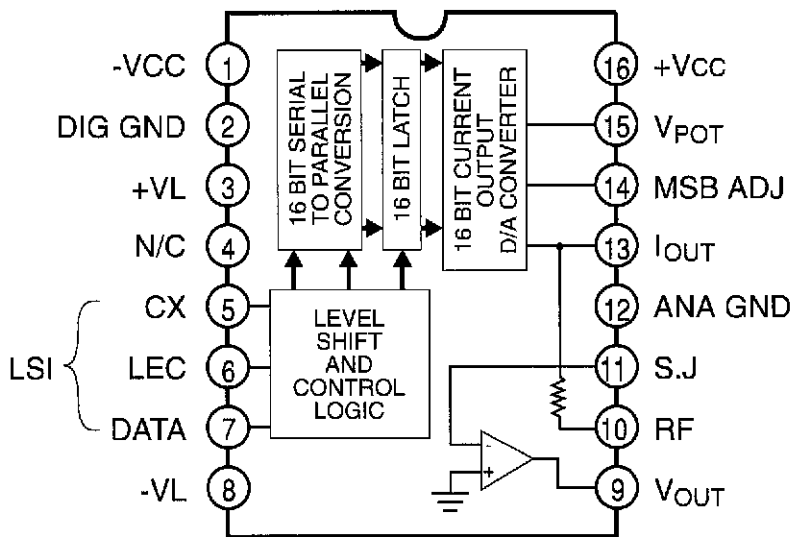

**IC801 : T74HC02P
Buffer Amp.**

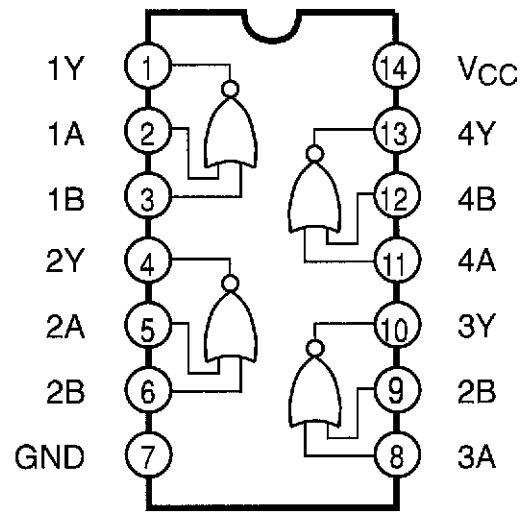

P. C. BOARDS (1)

PCB-1 MAIN

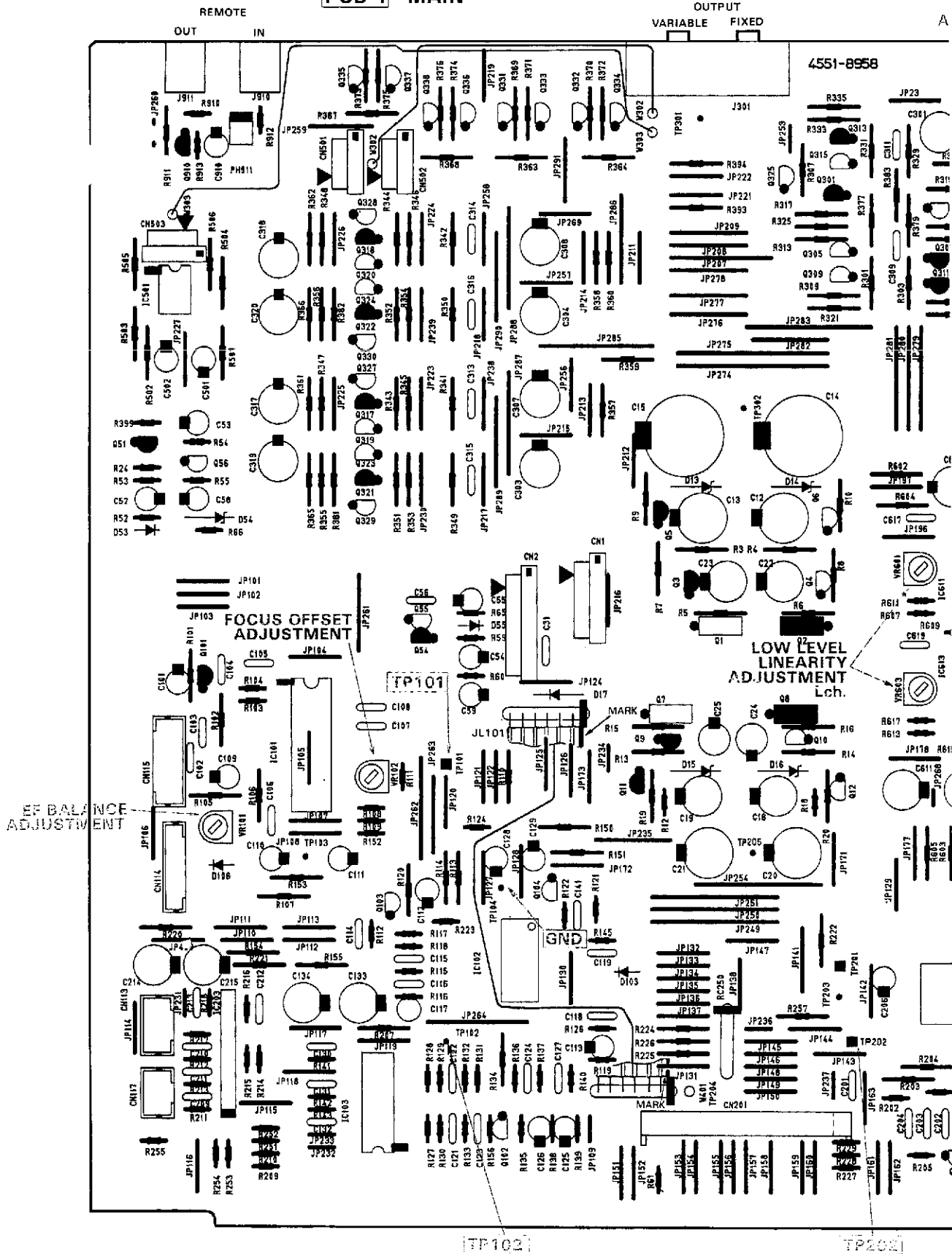

LOW LEVEL
LINEARITY
ADJUSTMENT
(Rch)

DIGITAL
OUTPUT
COAXIAL

SHIELD PLATE

PCB-2 FRONT

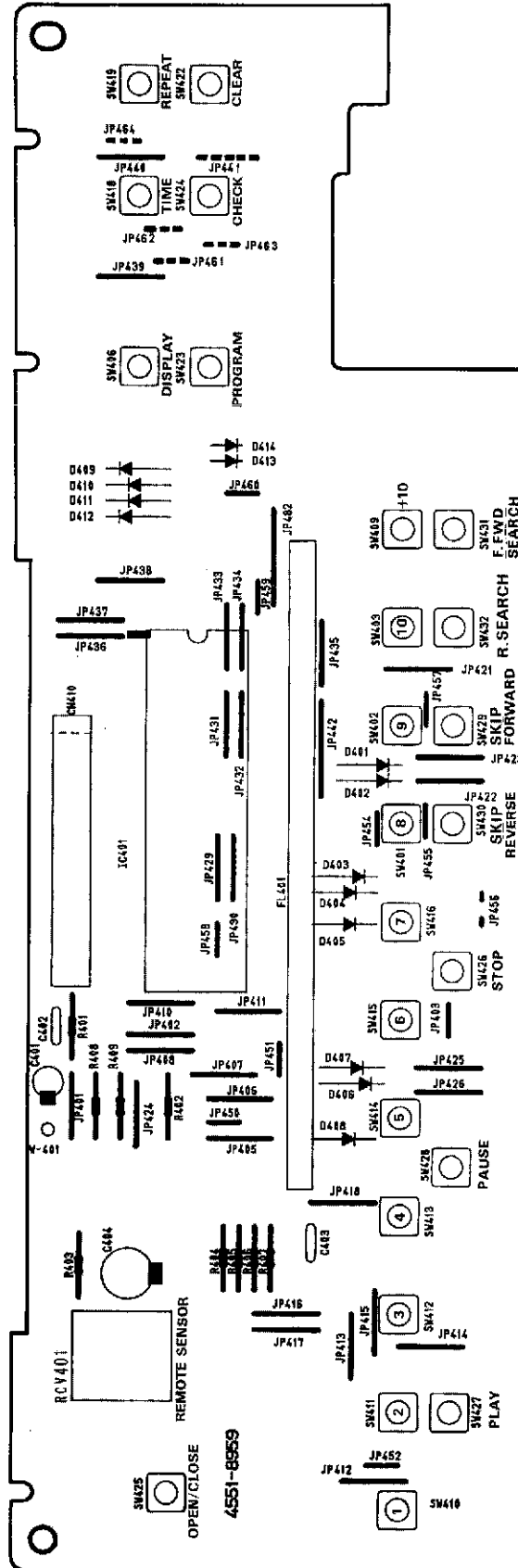
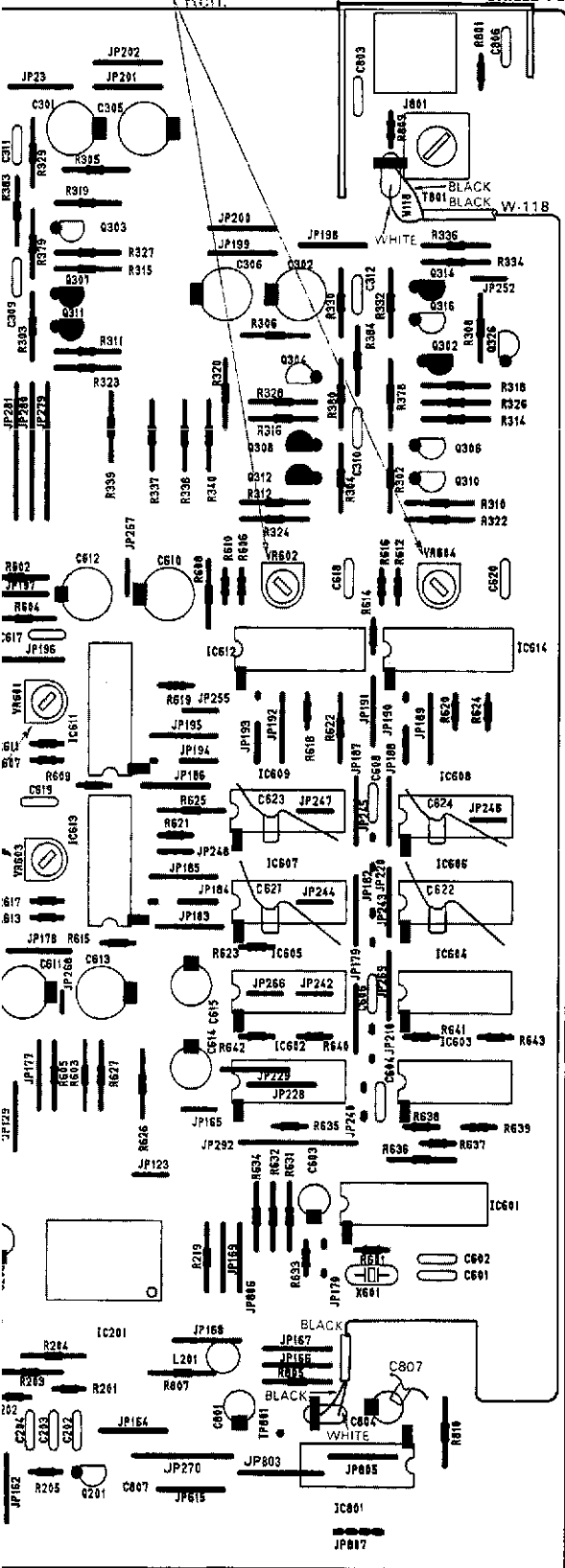

P. C. BOARDS (2)

PCB-4 POWER SUPPLY

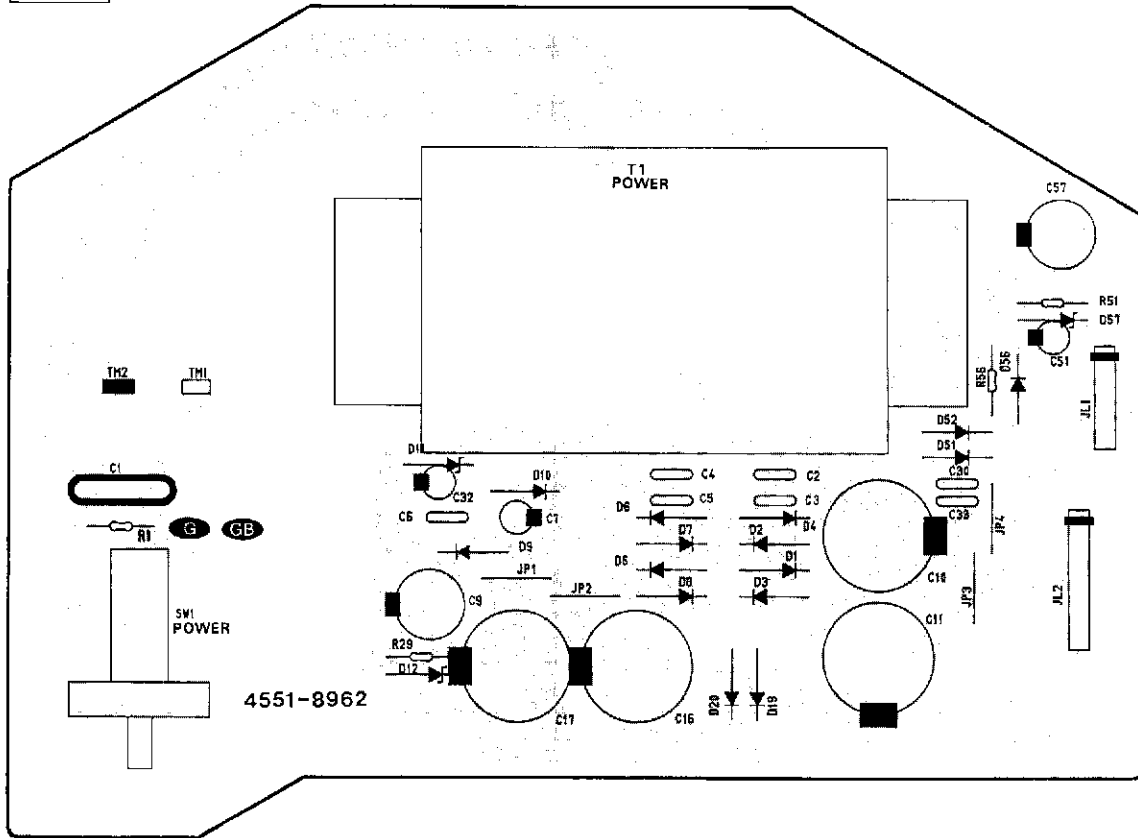

PCB-3 VOLUME

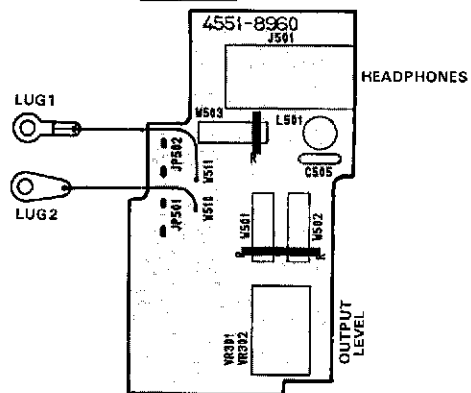

SCHEMATIC DIAGRAM (1)

SCHEMATIC DIAGRAM (1)

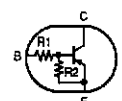
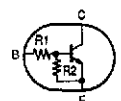
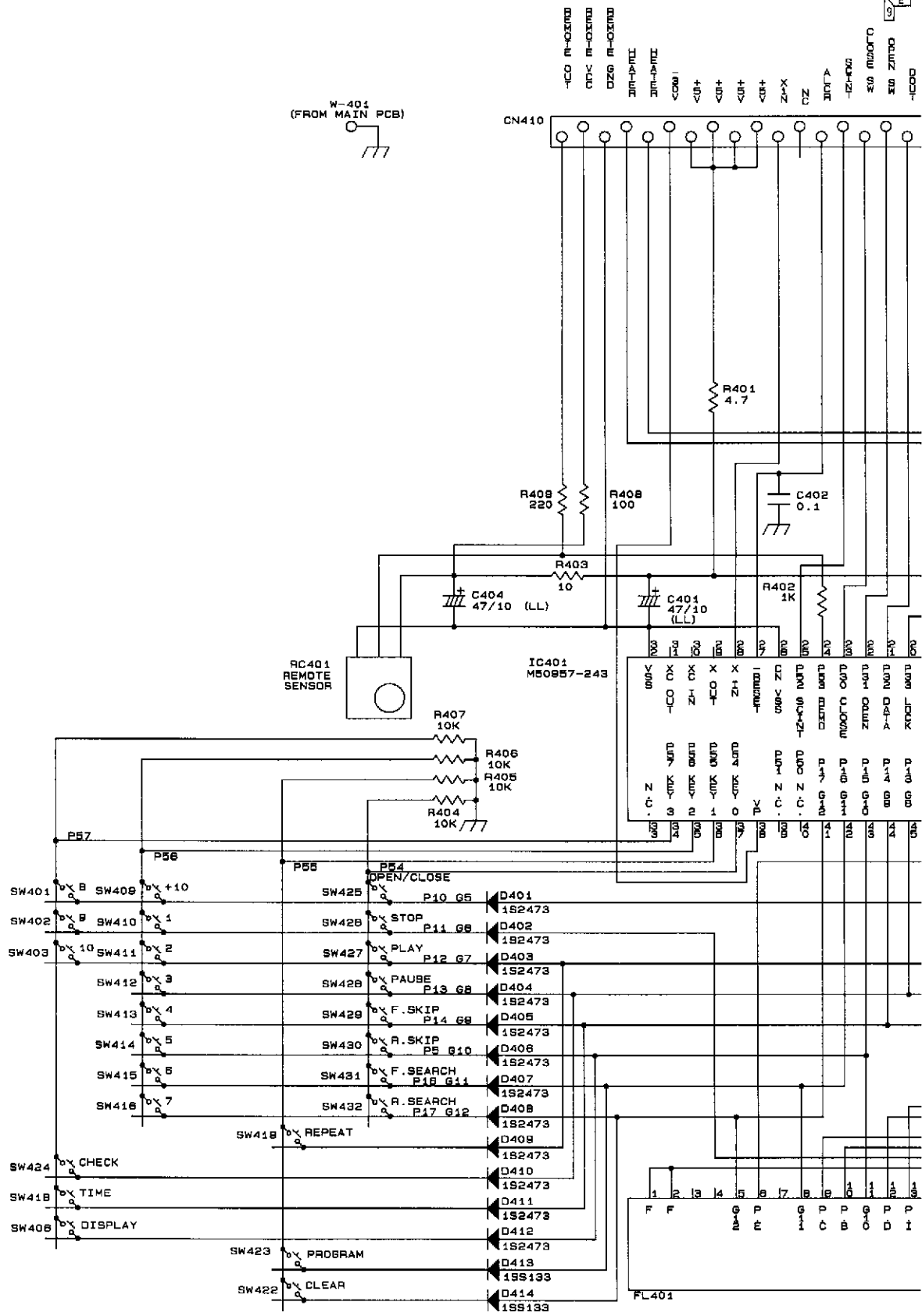

- NOTE :
- 1. A
 - 2. T
 - 3. A
 - 4. S
 - 5. T

Type	R1(kΩ)	R2(kΩ)
RN1202	10	10

Type	R1(kΩ)	R2(kΩ)
RN2201	10	10

SCHEMATIC
DIAGRAM (2)

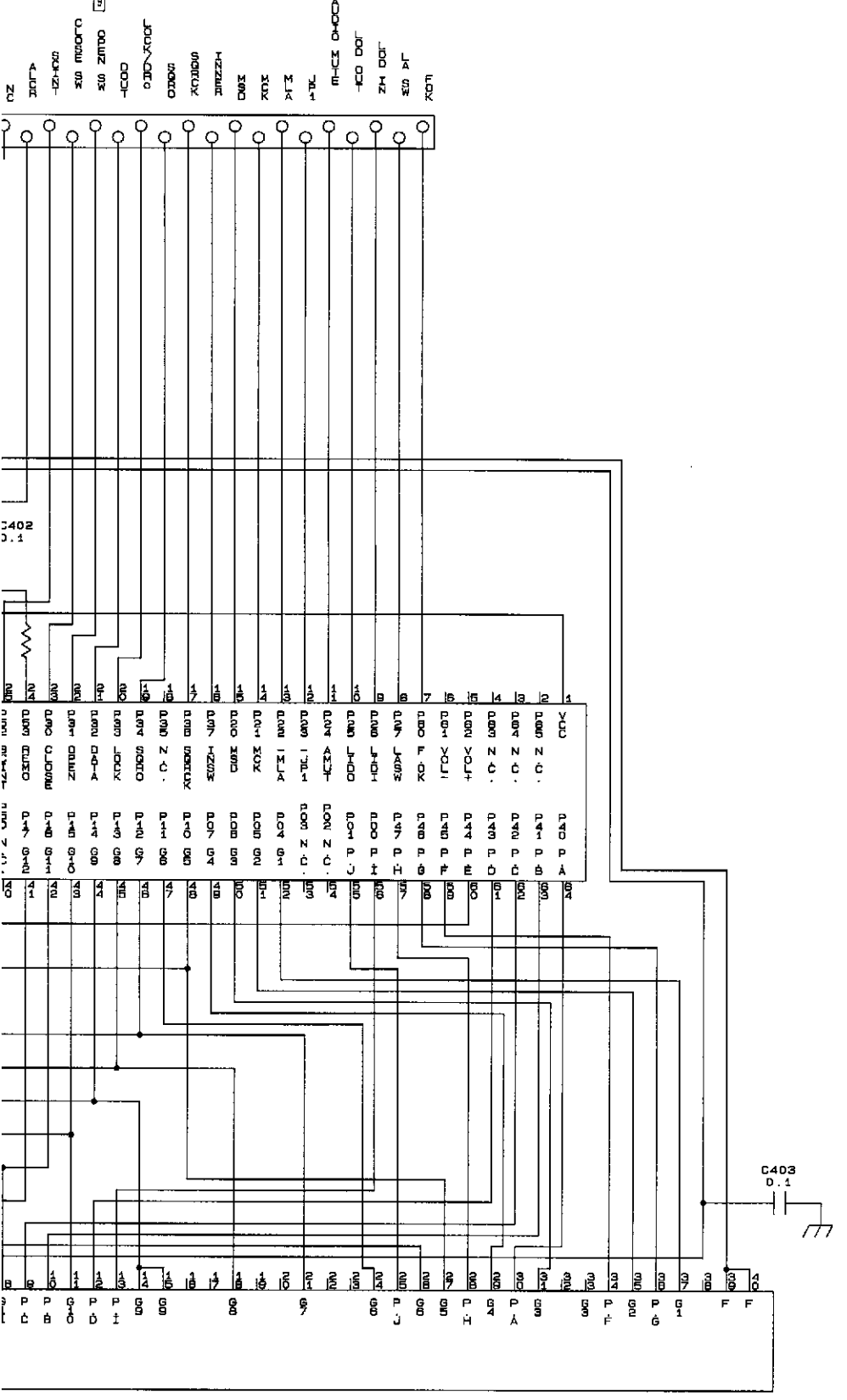

IC401

PIN NR.	PLAY	STOP	PIN NR.	PLAY	STOP
1	5.2	5.2	33		
2	0.0	0.0	34		
3	0.0	0.0	35		
4	0.0	0.0	36		
5	0.0	0.0	37		
6	0.0	0.0	38	-27.8	-27.3
7	3.7	0.1	39		
8	0.0	5.1	40		
9	0.0	0.0	41		
10	0.0	0.0	42		
11	8.5	0.0	43		
12	5.2	5.2	44		
13	5.2	5.2	45		
14	5.2	5.2	46		
15	5.2	5.2	47		
16	5.2	5.3	48		
17	5.3	5.2	49		
18	0.0	0.0	50		
19	0.0	5.0	51		
20	5.1	0.0	52		
21	5.2	0.0	53		
22	0.0	0.0	54		
23	5.2	5.2	55		
24	5.2	5.1	56		
25	5.0	5.1	57		
26	0.0	0.0	58		
27	5.2	5.2	59		
28	2.5	2.5	60		
29	2.3	2.2	61		
30	0.0	0.0	62		
31	5.1	5.1	63		
32	0.0	0.0	64		

- NOTE :
- ALL RESISTANCE VALUES ARE IN (ohm).
 - K=1000 (ohm) M=1000K (ohm)
 - THE WATTAGE OF RESISTANCES IS 1/4W UNLESS OTHERWISE NOTED.
 - ALL CAPACITANCES VALUES ARE IN uF UNLESS OTHERWISE NOTED.
 - SAFETY REQUIREMENTS COMPONENTS IN ACCORDANCE WITH PRESENT SAFETY REGULATIONS.
 - THESE COMPONENTS MUST ONLY BE REPLACED BY ORIGINAL PARTS.

SCHEMATIC DIAGRAM (2)

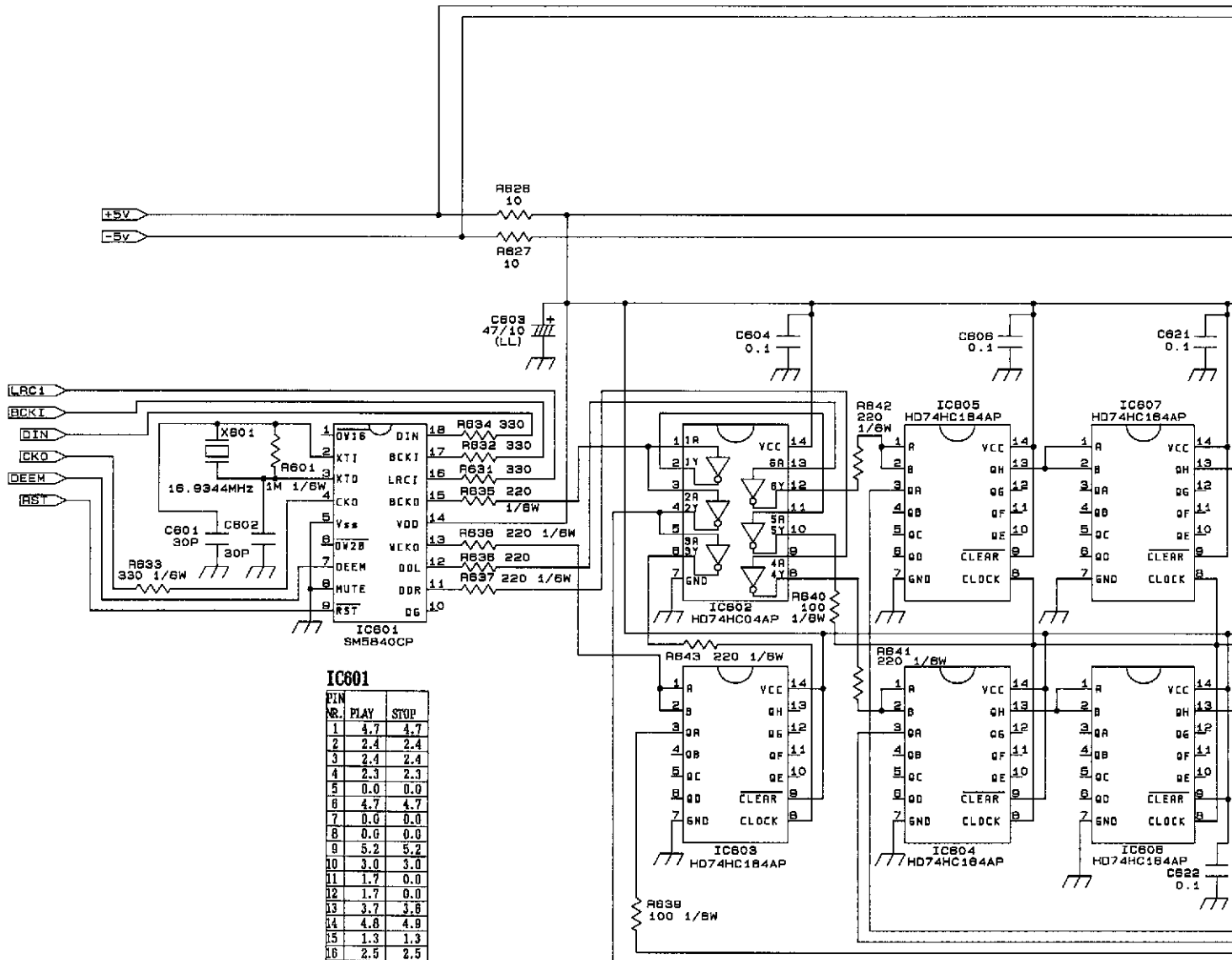

IC601

PIN NR.	PLAY	STOP
1	4.7	4.7
2	2.4	2.4
3	2.4	2.4
4	2.3	2.3
5	0.0	0.0
6	4.7	4.7
7	0.0	0.0
8	0.0	0.0
9	5.2	5.2
10	3.0	3.0
11	1.7	0.0
12	1.7	0.0
13	3.7	3.6
14	4.6	4.9
15	1.3	1.3
16	2.5	2.5
17	2.5	2.5
18	2.5	0.0

IC602			IC603			IC604			IC605			IC606			IC607		
PIN NR.	PLAY	STOP	PIN NR.	PLAY	STOP	PIN NR.	PLAY	STOP	PIN NR.	PLAY	STOP	PIN NR.	PLAY	STOP	PIN NR.	PLAY	STOP
1	1.4	1.4	1	3.6	3.6	1	3.0	4.9	1	3.0	4.9	1	2.4	4.9	1	2.4	4.9
2	3.1	3.2	2	3.6	3.6	2	3.0	4.9	2	3.0	4.9	2	2.4	4.9	2	2.4	4.9
3	1.4	1.4	3	3.8	3.8	3	2.4	4.9	3	2.4	4.9	3	2.4	4.9	3	2.4	4.9
4	3.1	3.2	4	3.8	3.8	4	2.4	4.9	4	2.4	4.9	4	2.4	4.9	4	2.4	4.9
5	3.1	3.2	5	3.8	3.8	5	2.4	4.9	5	2.4	4.9	5	2.4	4.9	5	2.4	4.9
6	1.6	1.6	6	3.8	3.8	6	2.4	4.9	6	2.4	4.9	6	2.4	4.9	6	2.4	4.9
7	0.0	0.0	7	0.0	0.0	7	0.0	0.0	7	0.0	0.0	7	0.0	0.0	7	0.0	0.0
8	3.0	4.9	8	1.6	1.6	8	1.6	1.6	8	1.6	1.6	8	1.6	1.6	8	1.6	1.6
9	1.7	0.0	9	4.8	4.9	9	4.8	4.9	9	4.8	4.9	9	4.8	4.9	9	4.8	4.9
10	1.6	1.6	10	3.8	3.8	10	2.4	4.9	10	2.4	4.9	10	2.4	4.9	10	2.4	4.9
11	3.1	3.2	11	3.8	3.8	11	2.4	4.9	11	2.4	4.9	11	2.4	4.9	11	2.4	4.9
12	3.0	4.9	12	3.8	3.8	12	2.4	4.9	12	2.4	4.9	12	2.4	4.9	12	2.4	4.9
13	1.7	0.0	13	3.8	3.8	13	2.4	4.9	13	2.4	4.9	13	2.4	4.9	13	2.4	4.9
14	4.8	4.9	14	4.8	4.9	14	4.8	4.9	14	4.8	4.9	14	4.8	4.9	14	4.8	4.9

NOTE :
 1. ALL RESISTANCES VALUES
 K=1000 [ohm], M=1000K
 2. THE WATTAGE OF RESISTAN
 3. ALL CAPACITANCES VALUES
 P=UF
 4. SAFETY REQUIREMENTS COM
 5. THESE COMPONENTS MUST C



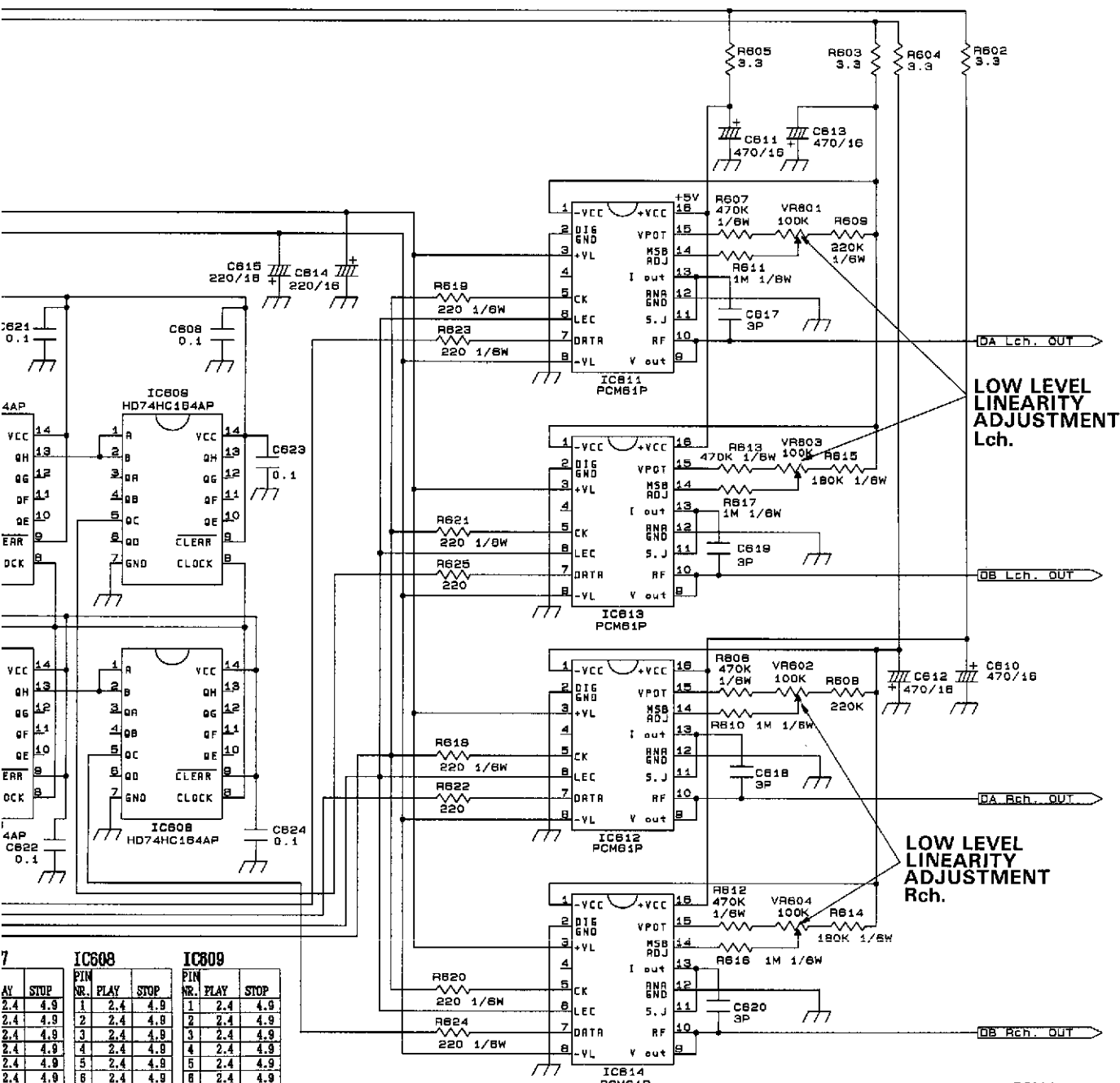

		IC608			IC609		
AV	STOP	PIN NR.	PLAY	STOP	PIN NR.	PLAY	STOP
2.4	4.9	1	2.4	4.9	1	2.4	4.9
2.4	4.9	2	2.4	4.9	2	2.4	4.9
2.4	4.9	3	2.4	4.9	3	2.4	4.9
2.4	4.9	4	2.4	4.9	4	2.4	4.9
2.4	4.9	5	2.4	4.9	5	2.4	4.9
2.4	4.9	6	2.4	4.9	6	2.4	4.9
0.0	0.0	7	0.0	0.0	7	0.0	0.0
1.8	1.8	8	1.8	1.8	8	1.8	1.8
4.8	4.9	9	4.8	4.9	9	4.8	4.9
2.4	4.8	10	2.4	4.8	10	2.4	4.8
2.4	4.9	11	2.4	4.9	11	2.4	4.9
2.4	4.9	12	2.4	4.9	12	2.4	4.9
2.4	4.9	13	2.4	4.9	13	2.4	4.9
4.8	4.9	14	4.8	4.9	14	4.8	4.9

IC611			IC612			IC613			IC614		
PIN NR.	PLAY	STOP	PIN NR.	PLAY	STOP	PIN NR.	PLAY	STOP	PIN NR.	PLAY	STOP
1	-5.1	-5.1	1	-5.1	-5.1	1	-5.1	-5.1	1	-5.1	-5.1
2	0.0	0.0	2	0.0	0.0	2	0.0	0.0	2	0.0	0.0
3	4.8	4.9	3	4.9	5.0	3	4.8	5.0	3	4.8	5.0
4	0.0	0.0	4	0.0	0.0	4	0.0	0.0	4	0.0	0.0
5	3.1	3.2	5	3.2	3.2	5	3.1	3.2	5	3.1	3.2
6	3.8	3.9	6	3.8	3.9	6	3.8	3.9	6	3.8	3.9
7	2.4	5.0	7	2.4	5.0	7	2.4	5.0	7	2.4	4.9
8	-4.7	-4.7	8	-4.8	-4.7	8	-4.7	-4.7	8	-4.7	-4.7
9	0.0	0.0	9	0.0	0.0	9	0.0	0.0	9	0.0	0.0
10	0.0	0.0	10	0.0	0.0	10	0.0	0.0	10	0.0	0.0
11	0.0	0.0	11	0.0	0.0	11	0.0	0.0	11	0.0	0.0
12	0.0	0.0	12	0.0	0.0	12	0.0	0.0	12	0.0	0.0
13	0.0	0.0	13	0.0	0.0	13	0.0	0.0	13	0.0	0.0
14	-2.6	-2.6	14	-2.5	-2.5	14	-2.6	-2.6	14	-2.6	-2.6
15	2.3	2.3	15	2.3	2.3	15	2.3	2.3	15	2.3	2.3
16	5.2	5.2	16	5.2	5.2	16	5.2	5.2	16	5.2	5.2

RESISTANCE VALUES ARE IN (ohm).
 M=1000K (ohm)
 RESISTANCES IS 1/4W UNLESS OTHERWISE NOTED.
 CAPACITANCE VALUES ARE IN uF UNLESS OTHERWISE NOTED.
 COMPONENTS IN ACCORDANCE WITH PRESENT SAFETY REGULATIONS.
 THIS MUST ONLY BE REPLACED BY ORIGINAL PARTS.

G

H

I

J

K

L

M

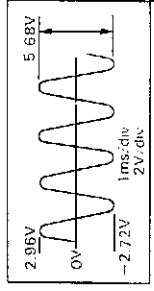
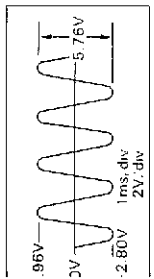

IC201	IC501	IC801
FR	FR	FR
PLAY	PLAY	PLAY
STOP	STOP	STOP
1	1	1
2	2	2
3	3	3
4	4	4
5	5	5
6	6	6
7	7	7
8	8	8
9	9	9
10	10	10
11	11	11
12	12	12
13	13	13
14	14	14
15	15	15
16	16	16
17	17	17
18	18	18
19	19	19
20	20	20
21	21	21
22	22	22
23	23	23
24	24	24
25	25	25
26	26	26
27	27	27
28	28	28
29	29	29
30	30	30
31	31	31
32	32	32
33	33	33
34	34	34
35	35	35
36	36	36
37	37	37
38	38	38
39	39	39
40	40	40

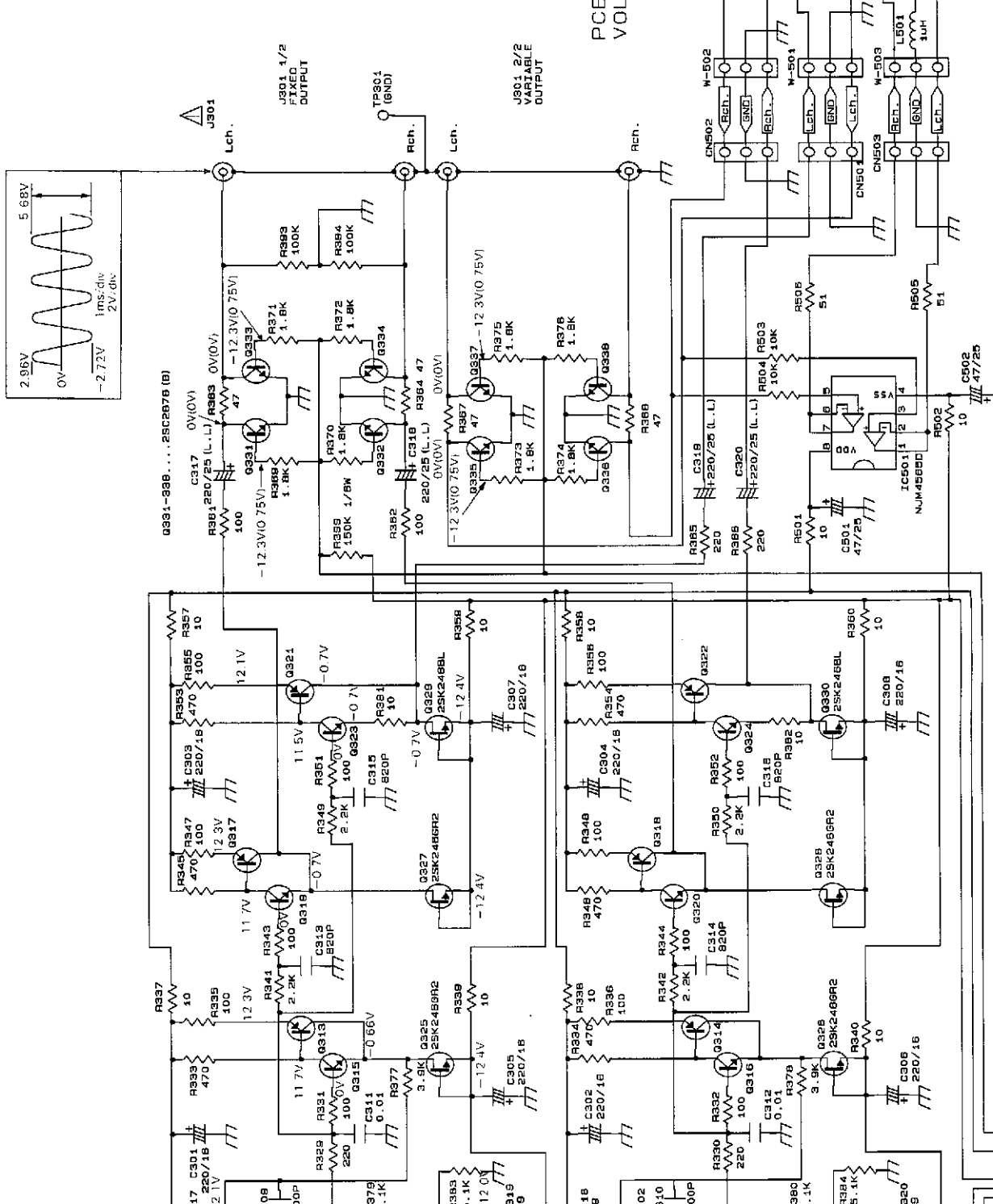

PCB-3
VOLUME

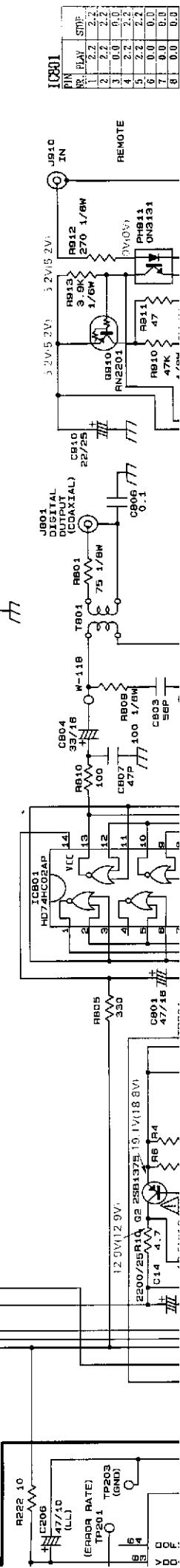

IC801	FR	PLAY	STOP
1	1	1	1
2	2	2	2
3	3	3	3
4	4	4	4
5	5	5	5
6	6	6	6
7	7	7	7
8	8	8	8

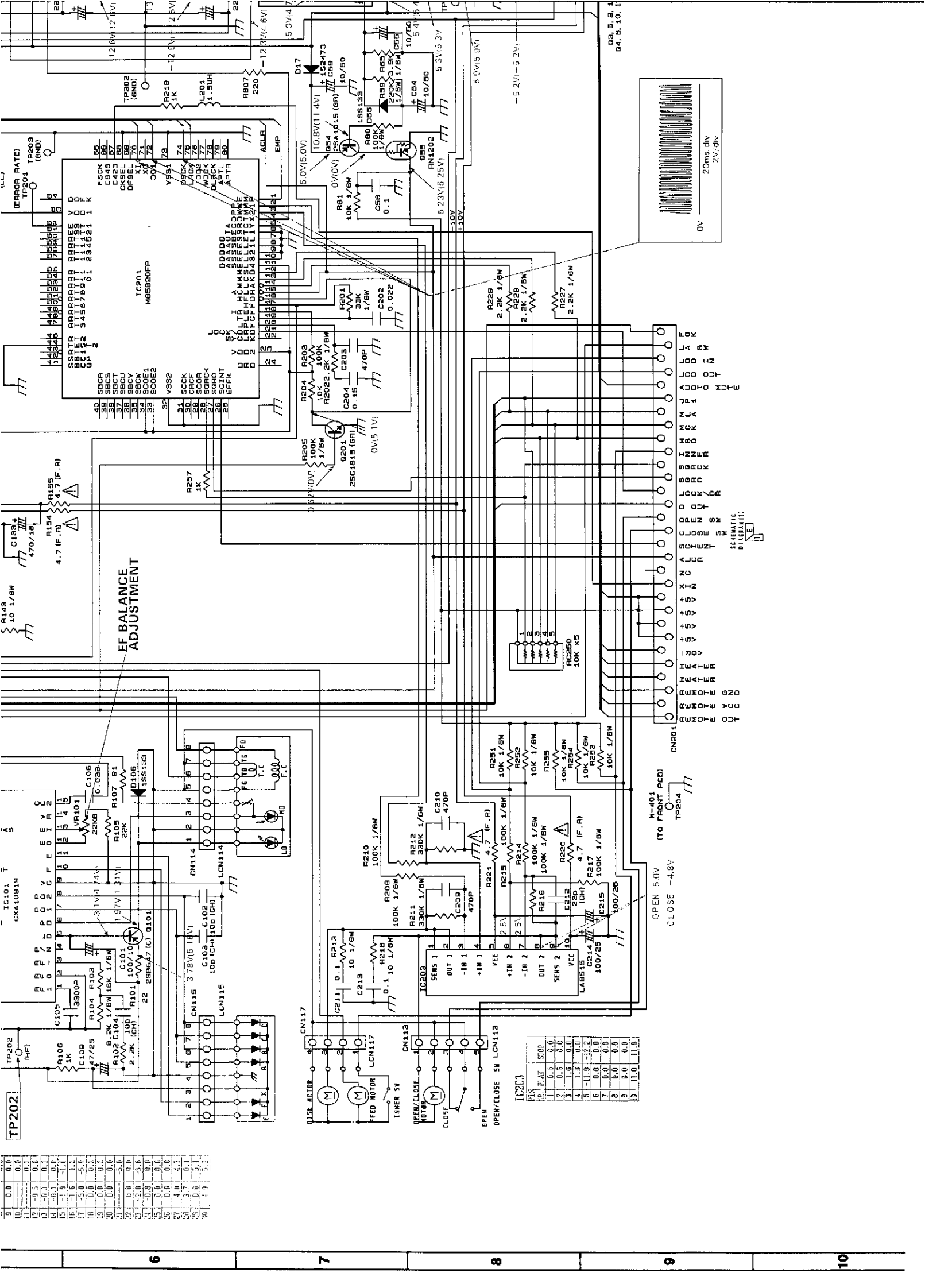

1	D.0	0.0
2	D.0	0.0
3	D.0	0.0
4	D.0	0.0
5	D.0	0.0
6	D.0	0.0
7	D.0	0.0
8	D.0	0.0
9	D.0	0.0
10	D.0	0.0
11	D.0	0.0
12	D.0	0.0
13	D.0	0.0
14	D.0	0.0
15	D.0	0.0
16	D.0	0.0
17	D.0	0.0
18	D.0	0.0
19	D.0	0.0
20	D.0	0.0
21	D.0	0.0
22	D.0	0.0
23	D.0	0.0
24	D.0	0.0
25	D.0	0.0
26	D.0	0.0
27	D.0	0.0
28	D.0	0.0
29	D.0	0.0
30	D.0	0.0

1	0.0	0.0
2	0.6	0.6
3	1.6	0.0
4	1.6	0.0
5	11.9	-12.2
6	0.0	0.0
7	0.0	0.0
8	0.0	0.0
9	0.0	0.0
10	11.0	11.0

0V
20ms/div
2V/div

SCHEMATIC
011638A(11)

1	D.0	0.0
2	D.0	0.0
3	D.0	0.0
4	D.0	0.0
5	D.0	0.0
6	D.0	0.0
7	D.0	0.0
8	D.0	0.0
9	D.0	0.0
10	D.0	0.0
11	D.0	0.0
12	D.0	0.0
13	D.0	0.0
14	D.0	0.0
15	D.0	0.0
16	D.0	0.0
17	D.0	0.0
18	D.0	0.0
19	D.0	0.0
20	D.0	0.0
21	D.0	0.0
22	D.0	0.0
23	D.0	0.0
24	D.0	0.0
25	D.0	0.0
26	D.0	0.0
27	D.0	0.0
28	D.0	0.0
29	D.0	0.0
30	D.0	0.0

6

7

8

9

10

PCB PART	QTY
1	2.2
2	2.2
3	2.2
4	2.2
5	2.2
6	2.2
7	2.2
8	2.2
9	2.4
10	2.2
11	0.0
12	2.2
13	2.2
14	4.6
15	4.6

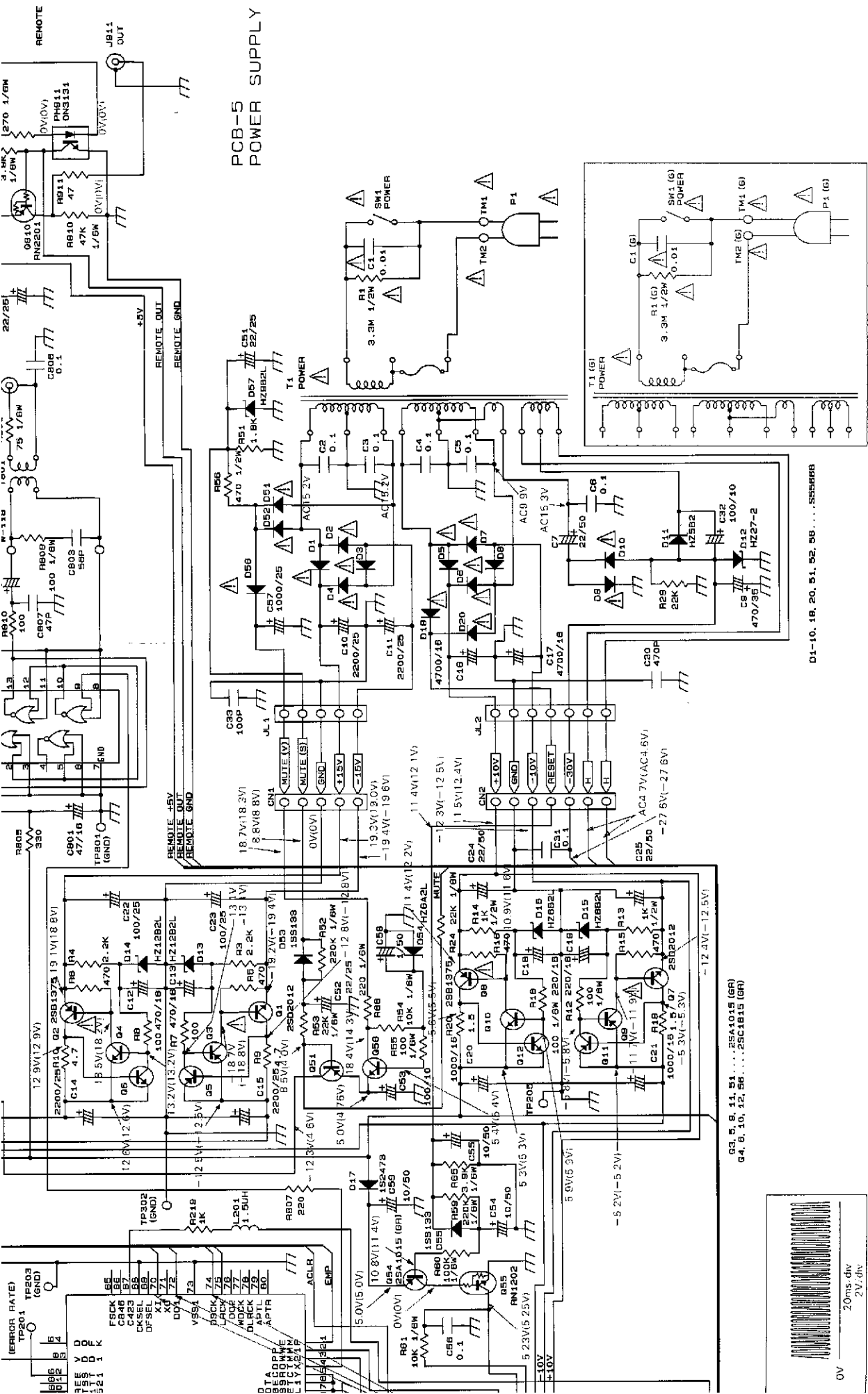

PCB-5
POWER SUPPLY

- NOTE:
1. ALL RESISTANCE VALUES ARE IN OHMS.
 2. THE MATTAGE OF RESISTANCES IS 1/4W UNLESS OTHERWISE NOTED.
 3. ALL CAPACITANCE VALUES ARE IN UF UNLESS OTHERWISE NOTED.
 4. SAFETY REGULATIONS COMPONENTS IN ACCORDANCE WITH PRESENT SAFETY REGULATIONS.
 5. THESE COMPONENTS MUST ONLY BE REPLACED BY ORIGINAL PARTS.

0V
20ms/div
2V/div

G3, 5, 8, 11, 51, 52, 55, 56, 58, 59, 60, 61, 62, 63, 64, 65, 66, 67, 68, 69, 70, 71, 72, 73, 74, 75, 76, 77, 78, 79, 80, 81, 82, 83, 84, 85, 86, 87, 88, 89, 90, 91, 92, 93, 94, 95, 96, 97, 98, 99, 100, 101, 102, 103, 104, 105, 106, 107, 108, 109, 110, 111, 112, 113, 114, 115, 116, 117, 118, 119, 120, 121, 122, 123, 124, 125, 126, 127, 128, 129, 130, 131, 132, 133, 134, 135, 136, 137, 138, 139, 140, 141, 142, 143, 144, 145, 146, 147, 148, 149, 150, 151, 152, 153, 154, 155, 156, 157, 158, 159, 160, 161, 162, 163, 164, 165, 166, 167, 168, 169, 170, 171, 172, 173, 174, 175, 176, 177, 178, 179, 180, 181, 182, 183, 184, 185, 186, 187, 188, 189, 190, 191, 192, 193, 194, 195, 196, 197, 198, 199, 200, 201, 202, 203, 204, 205, 206, 207, 208, 209, 210, 211, 212, 213, 214, 215, 216, 217, 218, 219, 220, 221, 222, 223, 224, 225, 226, 227, 228, 229, 230, 231, 232, 233, 234, 235, 236, 237, 238, 239, 240, 241, 242, 243, 244, 245, 246, 247, 248, 249, 250, 251, 252, 253, 254, 255, 256, 257, 258, 259, 260, 261, 262, 263, 264, 265, 266, 267, 268, 269, 270, 271, 272, 273, 274, 275, 276, 277, 278, 279, 280, 281, 282, 283, 284, 285, 286, 287, 288, 289, 290, 291, 292, 293, 294, 295, 296, 297, 298, 299, 300, 301, 302, 303, 304, 305, 306, 307, 308, 309, 310, 311, 312, 313, 314, 315, 316, 317, 318, 319, 320, 321, 322, 323, 324, 325, 326, 327, 328, 329, 330, 331, 332, 333, 334, 335, 336, 337, 338, 339, 340, 341, 342, 343, 344, 345, 346, 347, 348, 349, 350, 351, 352, 353, 354, 355, 356, 357, 358, 359, 360, 361, 362, 363, 364, 365, 366, 367, 368, 369, 370, 371, 372, 373, 374, 375, 376, 377, 378, 379, 380, 381, 382, 383, 384, 385, 386, 387, 388, 389, 390, 391, 392, 393, 394, 395, 396, 397, 398, 399, 400, 401, 402, 403, 404, 405, 406, 407, 408, 409, 410, 411, 412, 413, 414, 415, 416, 417, 418, 419, 420, 421, 422, 423, 424, 425, 426, 427, 428, 429, 430, 431, 432, 433, 434, 435, 436, 437, 438, 439, 440, 441, 442, 443, 444, 445, 446, 447, 448, 449, 450, 451, 452, 453, 454, 455, 456, 457, 458, 459, 460, 461, 462, 463, 464, 465, 466, 467, 468, 469, 470, 471, 472, 473, 474, 475, 476, 477, 478, 479, 480, 481, 482, 483, 484, 485, 486, 487, 488, 489, 490, 491, 492, 493, 494, 495, 496, 497, 498, 499, 500, 501, 502, 503, 504, 505, 506, 507, 508, 509, 510, 511, 512, 513, 514, 515, 516, 517, 518, 519, 520, 521, 522, 523, 524, 525, 526, 527, 528, 529, 530, 531, 532, 533, 534, 535, 536, 537, 538, 539, 540, 541, 542, 543, 544, 545, 546, 547, 548, 549, 550, 551, 552, 553, 554, 555, 556, 557, 558, 559, 560, 561, 562, 563, 564, 565, 566, 567, 568, 569, 570, 571, 572, 573, 574, 575, 576, 577, 578, 579, 580, 581, 582, 583, 584, 585, 586, 587, 588, 589, 590, 591, 592, 593, 594, 595, 596, 597, 598, 599, 600, 601, 602, 603, 604, 605, 606, 607, 608, 609, 610, 611, 612, 613, 614, 615, 616, 617, 618, 619, 620, 621, 622, 623, 624, 625, 626, 627, 628, 629, 630, 631, 632, 633, 634, 635, 636, 637, 638, 639, 640, 641, 642, 643, 644, 645, 646, 647, 648, 649, 650, 651, 652, 653, 654, 655, 656, 657, 658, 659, 660, 661, 662, 663, 664, 665, 666, 667, 668, 669, 670, 671, 672, 673, 674, 675, 676, 677, 678, 679, 680, 681, 682, 683, 684, 685, 686, 687, 688, 689, 690, 691, 692, 693, 694, 695, 696, 697, 698, 699, 700, 701, 702, 703, 704, 705, 706, 707, 708, 709, 710, 711, 712, 713, 714, 715, 716, 717, 718, 719, 720, 721, 722, 723, 724, 725, 726, 727, 728, 729, 730, 731, 732, 733, 734, 735, 736, 737, 738, 739, 740, 741, 742, 743, 744, 745, 746, 747, 748, 749, 750, 751, 752, 753, 754, 755, 756, 757, 758, 759, 760, 761, 762, 763, 764, 765, 766, 767, 768, 769, 770, 771, 772, 773, 774, 775, 776, 777, 778, 779, 780, 781, 782, 783, 784, 785, 786, 787, 788, 789, 790, 791, 792, 793, 794, 795, 796, 797, 798, 799, 800, 801, 802, 803, 804, 805, 806, 807, 808, 809, 810, 811, 812, 813, 814, 815, 816, 817, 818, 819, 820, 821, 822, 823, 824, 825, 826, 827, 828, 829, 830, 831, 832, 833, 834, 835, 836, 837, 838, 839, 840, 841, 842, 843, 844, 845, 846, 847, 848, 849, 850, 851, 852, 853, 854, 855, 856, 857, 858, 859, 860, 861, 862, 863, 864, 865, 866, 867, 868, 869, 870, 871, 872, 873, 874, 875, 876, 877, 878, 879, 880, 881, 882, 883, 884, 885, 886, 887, 888, 889, 890, 891, 892, 893, 894, 895, 896, 897, 898, 899, 900, 901, 902, 903, 904, 905, 906, 907, 908, 909, 910, 911, 912, 913, 914, 915, 916, 917, 918, 919, 920, 921, 922, 923, 924, 925, 926, 927, 928, 929, 930, 931, 932, 933, 934, 935, 936, 937, 938, 939, 940, 941, 942, 943, 944, 945, 946, 947, 948, 949, 950, 951, 952, 953, 954, 955, 956, 957, 958, 959, 960, 961, 962, 963, 964, 965, 966, 967, 968, 969, 970, 971, 972, 973, 974, 975, 976, 977, 978, 979, 980, 981, 982, 983, 984, 985, 986, 987, 988, 989, 990, 991, 992, 993, 994, 995, 996, 997, 998, 999, 1000.

WIRING DIAGRAM

